

# Adaptive Kalman filter for active magnetic bearings using softcomputing

Li Li, W.Kästner, F.Worlitz

Institut für Prozeßtechnik, Prozeßautomatisierung und Meßtechnik, Hochschule Zittau/Görlitz,  
Theodor-Körner-Allee 16, 02763, Zittau, Germany, l.li@hszg.de

**Abstract**—Magnetic bearings can not only solve the bearing wear and life problems but also reduce the loss and noise of bearing. However, the strong disturbance and noise from the system affects the control behavior. Based on the Kalman filter the influence of noise will be reduced. But the strong nonlinear and uncertainty of parameter of the magnetic bearings make it difficult to establish the estimation / prediction equation in Kalman filter. This paper presents a design method of system estimation / prediction for Kalman filter with using soft computing. Firstly, linear local model for axial magnetic bearing overall system will be deduced. Then a few system parameters, which is relative with nonlinear and uncertainty, will be obtained by a intelligence function, which uses soft computing algorithm as system identification. Finally, the identified system parameters will be used in state equation in Kalman filter. It aims at better filter performance and state estimation than the conventional linear Kalman filter.

## A. Introduction

Many works have shown, that AMBs have tremendous potential for many high speed industrial applications.

The new approach aims to get a better filter performance and system observer by introducing a Kalman filter. Because of the intense nonlinear performance of the magnetically suspended bearings, the traditional linear system model is difficult to guarantee the accuracy in comparison with the actual system, when the system is far from the working point. As a result the filter function will be reduced. Thus a new approach for a precise system prediction for Kalman filter will be searched.

The soft computing consists of fuzzy logic, artificial neural network, and neural fuzzy logic. In the method, the relationship between the large amount of input and output are established. As the widely used intelligent model, it is essentially one nonlinear model and is easy to describe a complicated dynamic system. It has been proved that soft computing model can identify arbitrary nonlinear system and system parameters with a high precision [2].

This paper demonstrates a soft computing variation of the system equation in Kalman filter, with experimental validation on a simulated active axial magnetic bearing. Despite its highly nonlinear and uncertain nature, the dynamics of AMB system are represented using an adaptive linear model with parameters that are identified by system identification with soft computing. In paragraph B a linear Kalman for this system will be introduced. In paragraph C the artificial neural networks are an important tool of the identification for the system parameters. In paragraph D a expert system, which is

based on fuzzy rule, using a radial basis function and the result from identification, will be designed for a adaptive Kalman filter. Lastly the simulation's result will be showed.

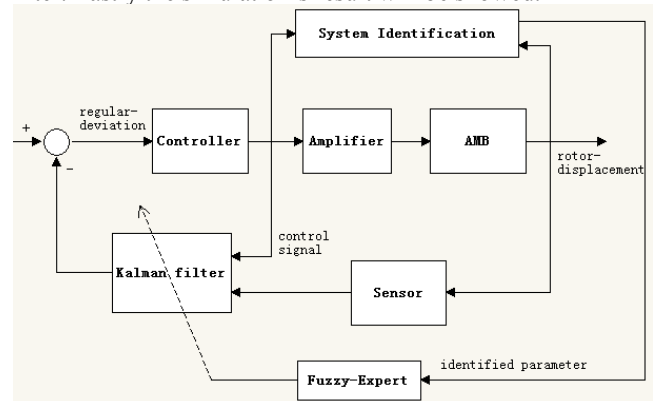

Fig 1: concept of the adaptive Kalman filtering in closed loop

## B. Traditional linear Kalman filter for magnet bearing

The first step of Kalman filter is to design the system state equation. This paragraph proposes linear discrete equation model on the basis of the force analysis of rotors and linearization of the magnetic force. The Kalman filter embodies the process - and measurement noise. We design a Kalman filter with the constant noise. Detailed analysis is listed as follows.

### Force Analysis of the Single Degree Axial Magnetic Bearing

In magnetic bearing system, single degree magnet poles are usually assembled symmetrically as showed in Fig2 a pair of electromagnetic forces opposite in direction is created simultaneously by adopting a pair of symmetric power amplification circuits and driving the electromagnet in differential mode. When the rotor is at the geometric center of the bearing, the distances between rotor and air gaps are  $s_0$ .

There is equal current  $i_0$ , which is also termed as magnetic biasing current between the upper and lower magnet poles to set up magnetic field. In any working state, if the rotor bias is  $x$ , then the air gap between rotor and lower magnet is  $s_0 + x$ . Accordingly, the air gap between rotor and lower magnet is  $s_0 - x$ . So the resultant force generated by this pair of magnet poles is: [3]

$$F_{Magnet} = k_{Magnet} \cdot \left[ \left( \frac{i_0 + i_u}{s_0 - x} \right)^2 - \left( \frac{i_0 - i_u}{s_0 + x} \right)^2 \right] = k_{Magnet} \cdot \frac{i_u^2}{x^2} \quad (1)$$

With using magnet parameter:  $k_{Magnet} = \frac{\mu_0 \cdot A \cdot N^2}{4}$

$\mu_0$  states for vacuum magnetic permeability, and A is the cross sectional area between core and air gap, N is turns of coil,  $i_u$  is control current.

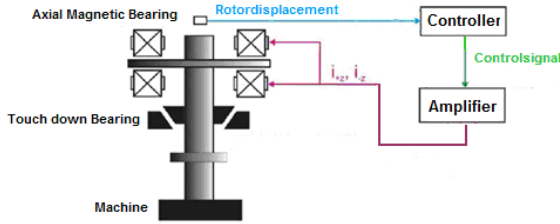

Fig 2: mode of single degree magnetic bearing

Plant physical parameters	
Mass of rotor	0.518 kg
Force const $k_{Magnet}$	$6.7 \text{ N} \cdot \text{mm}^2 / \text{A}^2$
Total air gap	5 mm
Nominal air gap $s_0$	2 mm
Nominal current $i_0$	1.5 A

Table 1: parameter and value about experiment system

According to *Newton Second Law*, the motion differential equation of single degree magnetic bearing is:

$$F_{Magnet} - m_{Rotor} \cdot g + F_{St} = m_{Rotor} \cdot \ddot{x} \quad (2)$$

$F_{St}$  is the disturbance force.

### Linearization of the magnetic force

By taking the Taylor's series expansion of equation (1) for arbitrary operating points  $(x^*, i_u^*)$ , the nonlinear equations of the magnetic force can be represented by the following equation:

$$F_{Magnet} = k_{Magnet} \cdot \frac{i_u^2}{x^2} = k_i |_{(s_0, i_0)} \cdot i_u + k_s |_{(s_0, i_0)} \cdot x \quad (3)$$

With linear approximation with respect to an equilibrium point  $(s_0, i_0)$ , position stiffness  $k_s$  and current stiffness  $k_i$  are given by the following:

$$k_i |_{(s_0, i_0)} = \frac{\partial F_{Magnet}}{\partial i} = 2 \cdot k_{Magnet} \cdot \frac{i_0}{s_0^2} \quad (4)$$

$$k_s |_{(s_0, i_0)} = \frac{\partial F_{Magnet}}{\partial s} = -2 \cdot k_{Magnet} \cdot \frac{i_0^2}{s_0^3} \quad (5)$$

Because of the intense nonlinear performance of the magnet force, the traditional linearization of the force with the constant stiffness  $k_i$  and  $k_s$  is difficult to guarantee the long-term accuracy, which is showed by the work [4].

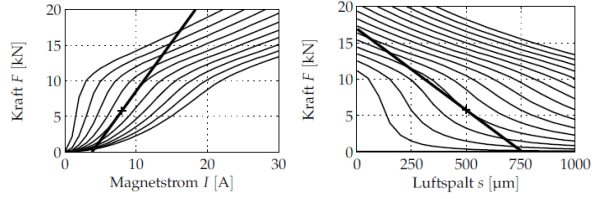

Fig 3: nonlinear performance of the magnet force [4]

According to this reason, the linear magnet force is not equal to the real magnet force, when the work point is far from the equilibrium point.

$$F_{Magnet} = k_{Magnet} \cdot \frac{i_u^2}{x^2} \neq k_i |_{(s_0, i_0)} \cdot i_u + k_s |_{(s_0, i_0)} \cdot x \quad (6)$$

### Review of Kalman filter

In many cases, particularly in industrial practice, PID regulators are implemented for this purpose [5]. Considering the fact that measured rotor position signal typically contain amount of high-frequency measurement noise, a reliable filter with prediction function is desired, Kalman filter goes without differentiation.

The process of designing an optimal state estimator for a magnetic levitation system can be summed up in four main steps-choosing an appropriate filter algorithm, determining the discrete-time state-space model and noise variance. Those steps are outlined subsequently. [5]

In general, a discrete-time process model with stochastic disturbance will be given as:

System state equation:

$$X(k+1) = f_k(X(k), u(k)) + v(k) \quad (7)$$

Measurement equation:

$$Y(k+1) = h_k(X(k)) + n(k) \quad (8)$$

With the state vector  $X(k)$ , the input value  $u(k)$ , the output vector (measurement)  $Y(k)$  at the time step k.  $v(k)$  and  $n(k)$  are the uncorrelated process noise and measurement noise. A Kalman filter consists of two parts, prediction step and correction step.

As the prediction step:

System state estimation:

$$X(k|k-1) = \bar{A} \cdot X(k-1|k-1) + \bar{B} \cdot u(k) \quad (9)$$

Covariance matrix estimation:

$$P(k|k-1) = \bar{A} \cdot P(k-1|k-1) \cdot \bar{A}^T + Q \quad (10)$$

As the correction step:

Calculation for Kalman gain:

$$K(k) = P(k|k-1) \cdot \bar{H}^T \cdot (\bar{H} \cdot P(k|k-1) \cdot \bar{H}^T + R)^{-1} \quad (11)$$

Optimal estimation for next step:

$$X(k|k) = X(k|k-1) + K(k) \cdot (Z(k) - \bar{H} \cdot X(k|k-1)) \quad (12)$$

Optimal covariance matrix:

$$P(k|k) = (\bar{I} - K_k \cdot \bar{H}) \cdot P(k|k-1) \quad (13)$$

The notation k|k-1 denotes an estimation at the time step k with measurement information from time step k-1. The notation k-1|k-1 denotes an optimal measurement at the time step k-1. A is system matrix, B is input matrix, H is measurement vector, P is covariance matrix of the estimation error, Q and R are system noise covariance matrix and measurement noise covariance matrix.

### Kalman filter of magnetic bearing system

The active magnetic bearing treated in this paper is an axial bearing (see Fig 2). The electromagnetic force acting on the rotor in bearing axis, which is a function of axial rotor position  $x$  and control current  $i$ , can be calculated by

$$F_{Magnet} = k_i |_{(s_0, i_0)} \cdot i_u + k_s |_{(s_0, i_0)} \cdot x \quad (14)$$

The rotor position is linked to the magnetic force and disturbance force. It is connected to the magnet force, disturbance force, "delayed" rotor position and velocity by the discrete equation:

$$x(k+1) = x(k) + T \cdot v(k) + \frac{1}{2} \cdot (F_{Magnet} + F_{St}) \cdot \frac{T^2}{m_{Rotor}} \quad (15)$$

The rotor velocity can be described by:

$$\dot{x}(k+1) = v(k) + (F_{Magnet} + F_{St}) \cdot \frac{T}{m_{Rotor}} \quad (16)$$

The magnet force will be described by (3). The control current of the coil is generated by the control signal  $u$  from controller, and the magnetic force can be described by:

$$F_{Magnet} = k_i |_{(s_0, i_0)} \cdot k_{ui} \cdot u + k_s |_{(s_0, i_0)} \cdot x \quad (17)$$

For generating the measuring signal, the state signal will be delayed. The sensor is modeled as a first-order lag element with the equivalent time constant  $T_{Sen}$  and proportional gain  $K_{Sen}$ . The "delayed" rotor position  $x_M$  is connected to the undelayed rotor position  $x$  by the differential equation:

$$x_M = \frac{K_{Sen}}{1 + p \cdot T_{Sen}} \cdot x \quad (18)$$

In discrete form it will be described as:

$$x_M(k+1) = K_{Sen} \cdot (1 - e^{-T/T_{Sen}}) \cdot x(k) + e^{-T/T_{Sen}} \cdot x_M(k) \quad (19)$$

Active magnetic bearings are well known as nonlinear systems. But in general, active magnetic bearings are regarded as linear system. Thus, an estimation algorithm will be used, which regards the system as a linear system using a linear state space model. The equation (14)-(19) describe the 4 state variables of the system. They can be combined to the time discrete state space model:

$$\begin{bmatrix} x(k+1) \\ v(k+1) \\ F_{St}(k+1) \\ X_M(k+1) \end{bmatrix} = \begin{bmatrix} 1 + \frac{k_s \cdot T^2}{2 \cdot m_{Rotor}} & T & \frac{T^2}{2 \cdot m_{Rotor}} & 0 \\ \frac{T \cdot k_s}{m_{Rotor}} & 1 & \frac{T}{m} & 0 \\ 0 & 0 & 1 & 0 \\ K_{Sen} \cdot (1 - e^{-T/T_{Sen}}) & 0 & 0 & e^{-T/T_{Sen}} \end{bmatrix} \cdot \begin{bmatrix} x(k) \\ v(k) \\ F_{St}(k) \\ X_M(k) \end{bmatrix} + \begin{bmatrix} \frac{k_i \cdot k_{ui} \cdot T^2}{2 \cdot m_{Rotor}} \\ \frac{T \cdot k_i \cdot k_{ui}}{m_{Rotor}} \\ 0 \\ 0 \end{bmatrix} \cdot u(k) \quad (20)$$

The observation equation is:

$$y(k) = \begin{bmatrix} 0 & 0 & 0 & 1 \end{bmatrix} \cdot \begin{bmatrix} x(k) \\ v(k) \\ F_{St}(k) \\ X_M(k) \end{bmatrix} \quad (21)$$

Choice of measurement noise variance  $R$  is a quite simple problem, if a sequence of the Gaussian signal noise can be measured. For the experiments,  $R$  is the noise variance matrix of sensor  $R = \text{diag}(\text{var}_{Sensor})$ . The process variance matrix  $Q$  will be calculated as:  $Q = \bar{B} \cdot \text{var}_{Process} \cdot \bar{B}^T$ . For the element in matrix  $Q$ , which is relative with estimated disturbance, will be experimentally initialized.

Besides the undisturbed rotor position signal, the Kalman filter yields the remaining state variables, rotor velocity, disturbance force and measurement signal. The combination of a Kalman filter as a state estimator in process is depicted in Fig 4.

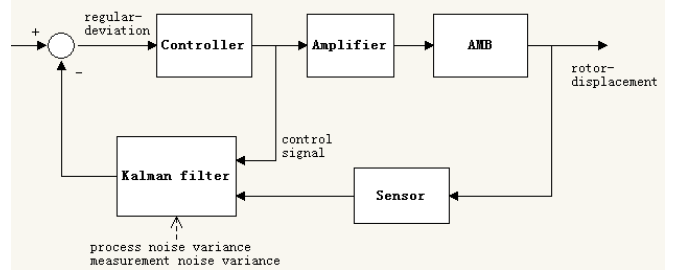

Fig 4: structure of kalman filter in process

### C. System identification with using softcomputing

It is well known that active magnetic bearings are inherently unstable systems due to the indirect proportionality between the attractive force and the length of the air gap [5]. In addition, the uncertainty of the magnetic force, which is caused by the changed magnetic field, has effect on the calculating of the magnetic force. Thus a identification of the parameter  $k_{Magnet}$ , furthermore of  $k_i$  and  $k_s$ , are necessary.

### Identification the system parameter

A neural network is a massively parallel distributed processor made up of simple processing units, called neurons, which has the natural propensity for storing experiential knowledge and making it available for use. And system identification, in general, is to determine the model structure and parameters for a dynamic system based on the measurable input and output data of the system. [7] Model structure in its classic form is multi input single output (MISO) linear system. The mathematical description of the used structure and adaptation law of the ADALINE (Adaptive Linear Element Neural Network) is presented in this section.

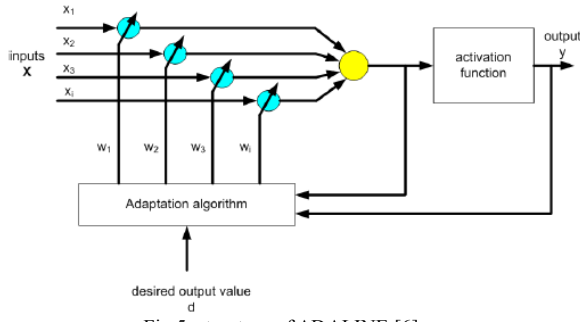

Fig 5: structure of ADALINE [6]

Output signal  $y(k)$  for ADALINE model is described by equations (without bias value):

$$y(k) = f(u(k)) \quad (22)$$

$$u(k) = \sum_{i=1}^N x_i(k) \cdot w_i(k) \quad (23)$$

Where  $f$  – activation function,  $w_i$  – weights coefficients,  $x_i$  – input signals,  $u$  – argument of the function. The online weight adaptation algorithm is realized in each iteration. All weight coefficients  $w_i$  are calculated according to the following equation: [6]

$$w_i(k+1) = w_i(k) + \Delta w_i(k), \text{ with } k=0, 1, 2, \dots$$

Detail of the net training can be found in [6] and [7]. In this work, a ADALINE will be used for the online identification of linear time varying systems, which can be described by a discrete time model.

For axial magnetic supported rotor, the system (rotor dynamic - magnet force) can be presented as a MISO system:

$$x(k+1) = \bar{x} \cdot \bar{w}^T = \quad (24)$$

$$x(k) + T \cdot v(k) + \frac{1}{2} \cdot \frac{T^2}{m_{Rotor}} \cdot F_{St}(k) + \frac{1}{2} \cdot \frac{T^2}{m_{Rotor}} \cdot F_{Magnet}(k)$$

In such systems, the system input vector

$$\bar{x} = [x(k), v(k), F_{St}(k), 1]^T$$

Weight vector:

$$\bar{w} = \left[ 1, T, \frac{1}{2} \cdot \frac{T^2}{m_{Rotor}}, \frac{1}{2} \cdot \frac{T^2}{m_{Rotor}} \cdot F_{Magnet}(k) \right]^T$$

Single output:

$$[x(k+1)]$$

In this example the weight parameter (magnet force)  $w_4 = F_{Magnet}(k)$  will be adapted and identified.

For magnet force, the system (magnet force – current and air gap) can be presented as a SISO system:

$$F_{Magnet}(k) = \bar{x} \cdot \bar{w}^T = \quad (25)$$

$$\left[ \left( \frac{i_0 + i_u(k)}{s_0 - x(k)} \right)^2 - \left( \frac{i_0 - i_u(k)}{s_0 + x(k)} \right)^2 \right] \cdot k_{Magnet}(k)$$

In such systems, the system input vector is just with one element:

$$\bar{x} = \left[ \left( \frac{i_0 + i_u(k)}{s_0 - x(k)} \right)^2 - \left( \frac{i_0 - i_u(k)}{s_0 + x(k)} \right)^2 \right]$$

Weight vector:

$$\bar{w} = [k_{Magnet}(k)]^T$$

Single output:

$$[F_{Magnet}(k)]$$

In this example the weight parameter (magnet parameter)  $w = k_{Magnet}(k)$  will be adapted and identified.

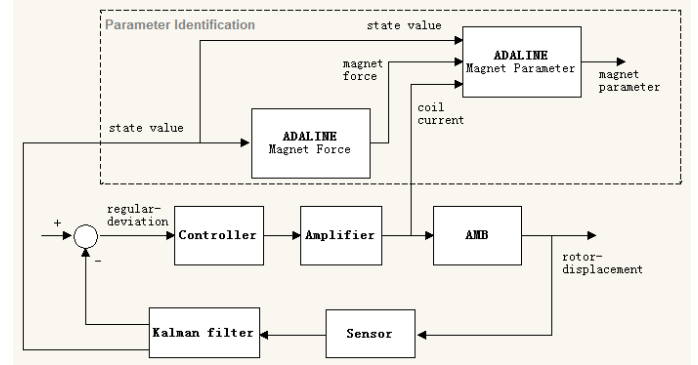

Fig 6: ADALINE used in system identification

### Identification of the parameter for working point

The active magnetic bearing system is uncertain, nonlinear and unstable. The most useful approach of dealing with such a system is to linearize it about a single nominal equilibrium point. In this work, we apply least square method (LSM) to obtain the stiffness parameter of the different work point. In order to present the overall system, the work point shall be chosen from the F-(i, s)-map.

The nodes of control current will be chosen as:

control current $i_u$	
$i_{u1} = -1.5A$	$i_{u2} = -0.75A$
$i_{u3} = 0A$	$i_{u4} = 0.75A$
$i_{u5} = 1.5A$	

Table 2: chosen value of control current

The nodes of rotor displacement will be chosen as:

rotor displacement $x$	
$x_1 = -0.5mm$	$x_2 = -0.25mm$
$x_3 = 0mm$	$x_4 = 0.25mm$
$x_5 = 0.5mm$	

Table 3: chosen value of rotor displacement

To obtain a linear model of every work point  $(i_{u|m}, x_n)$ , with  $m \in [1,5]$  and  $n \in [1,5]$ , which means the number of the input – fuzzy set. The magnet force must be linearized. The equation will be used:

$$F_{Magnet} |_{n,m} = k_i |_{(x_n, i_{u|m})} \cdot i_u + k_s |_{(x_n, i_{u|m})} \cdot x \quad (26)$$

The parameters of this linearized model will not vary with rotor position, when the work point is not far from the set point. For these work points, the process will be presented as:

$$F_{Magnet} |_{n,m} = k_i |_{(x_n, i_{u|m})} \cdot (i_u + \Delta i_u) + k_s |_{(x_n, i_{u|m})} \cdot (x + \Delta x) \quad (27)$$

With  $|\Delta i_u| \leq 0.01A$ , and  $|\Delta x| \leq 0.01mm$ . The work point series can be written as 9 equations:

$$F_{Magnet-1} |_{n,m} = k_i |_{(x_n, i_{u|m})} \cdot (i_u - 0.01) + k_s |_{(x_n, i_{u|m})} \cdot (x - 0.01)$$

$$F_{Magnet-2} |_{n,m} = k_i |_{(x_n, i_{u|m})} \cdot (i_u - 0.01) + k_s |_{(x_n, i_{u|m})} \cdot (x)$$

$$F_{Magnet-3} |_{n,m} = k_i |_{(x_n, i_u/m)} \cdot (i_u - 0.01) + k_s |_{(x_n, i_u/m)} \cdot (x + 0.01)$$

⋮

$$F_{Magnet-8} |_{n,m} = k_i |_{(x_n, i_u/m)} \cdot (i_u + 0.01) + k_s |_{(x_n, i_u/m)} \cdot (x)$$

$$F_{Magnet-9} |_{n,m} = k_i |_{(x_n, i_u/m)} \cdot (i_u + 0.01) + k_s |_{(x_n, i_u/m)} \cdot (x + 0.01)$$

A weight vector does there exist with two constand values:

$$\theta = \left[ k_i |_{(x_n, i_u/m)} \quad k_s |_{(x_n, i_u/m)} \right]$$

The input matrix:

$$\bar{A} = \begin{bmatrix} i_u - 0.01 & x - 0.01 \\ i_u - 0.01 & x \\ \vdots & \vdots \\ i_u + 0.01 & x + 0.01 \end{bmatrix}$$

The output vector:

$$Y = \begin{bmatrix} F_{Magnet-1} |_{n,m} \\ F_{Magnet-2} |_{n,m} \\ \vdots \\ F_{Magnet-9} |_{n,m} \end{bmatrix}$$

Consider the given set of samples  $\theta$ ,  $\bar{A}$  and  $Y$ , with least square method (LSM), the relation underlying the data set is represented as a function of the following form:

$$Y = \bar{A} \cdot \theta^T + e \quad (28)$$

Here  $e$  is the error for every equation. For the LSM regression, the error variables for the fitting problem will be introduced as follows:

$$e = Y - \bar{A} \cdot \theta^T \quad (29)$$

And for the given data those weights  $\theta$  will be searched, in which the summed quadratic error  $E$  of the training samples is smallest. The quadratic error is given as:

$$E(\theta) = \sum_{i=1}^m (y_i - a_i \cdot \theta)^2 = e^T \cdot e = (Y - \bar{A} \cdot \theta)^T \cdot (Y - \bar{A} \cdot \theta) \quad (30)$$

When the quadratic error is minimal,  $E(\theta) \rightarrow 0$ , the weights  $\theta$  shall be:

$$\theta = (A^T \cdot A)^{-1} \cdot A^T \cdot Y \quad (31)$$

The Fig 7 shows a schematic of the parameter identification process for stiffness parameter, when the identified magnet parameter is identified as:

$$k_{Magnet} \approx 6.7 \frac{N \cdot mm^2}{A^2}$$

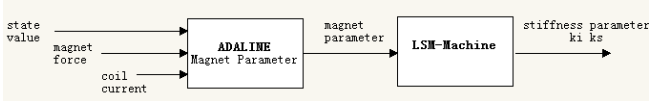

Fig 7: demodulation of the parameter identification with LSM

The table illustrates the experimental result of the stiffness parameter for every nominal work point:

Parameter identification $k_i$		$i_u$ (A)				
		-1.5	-0.75	0	0.75	1.5
$x_{Rotor}$ (mm)	-0.5	7.14	8.47	12.15	9.35	8.74
	-0.25	9.47	9.58	10.53	9.69	9.65
	0	10.05	10.05	10.05	10.05	10.05
	0.25	9.66	9.69	10.53	9.58	9.48
	0.5	8.75	9.35	12.15	8.45	7.14

Table 4: identified parameter  $k_i$  for every sub space

Parameter identification $k_s$		$i_u$ (A)				
		-1.5	-0.75	0	0.75	1.5
$x_{Rotor}$ (mm)	-0.5	32.16	16.23	8.57	6.53	6.94
	-0.25	21.89	12.57	7.78	7.21	10.30
	0	15.08	9.42	7.53	9.42	15.08
	0.25	10.30	7.21	7.78	12.57	21.89
	0.5	6.95	6.53	8.57	16.23	32.16

Table 5: identified parameter  $k_s$  for every sub space

#### D. Kalman filter with Expert system

In this paragraph, we apply a expert system, which is based on fuzzy basis function neural network (FBFNN), to obtain the actual stiffness parameter over the entire clearance and control current area in state equation in Kalman filter.

#### Generation of expert system with using FBFNN

Fuzzy logic system (FLS) is a logic in form of many-valued-rules. The FLS can be expressed mathematically as a linear combination of the input and output, such as TSK-fuzzy-logic, as a nonlinear combination it can be a Mamdani-fuzzy-logic. Detail for the fuzzy theory can be found in [8].

The expert system uses the control current  $i_u$  and rotor displacement  $x_{Rotor}$  as input, the stiffness parameter  $k_i$  and  $k_s$  as output. As shown in Table 2 and Table 3, the input  $i_u$  and  $x_{Rotor}$  will be divided into 5 levels. The conclusion value will be captured from LSM-machine. The rule base is constructed with Mamdani-structure, and presented as follows:

If <control current  $i_u$  is ..., rotor displacement  $x_{Rotor}$  is ...>

Then <stiffness parameter  $k_i$  and  $k_s$  are ...>

A convenient way to list all rules, is to use a tabular representation from Table 4 and Table 5.

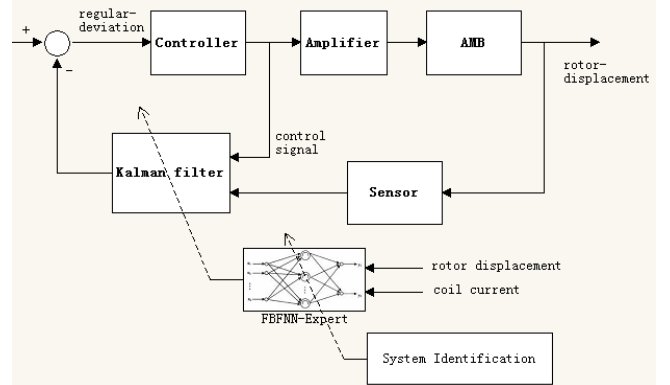

Fig 8: structure of adaptive kalman filter with using fuzzy expert system

#### Training of expert system with using FBFNN

RBFN is an adaptive network functionally equivalent to a fuzzy inference system. The fuzzy basis function (FBFNN) has if-then of membership functions in the neural network. As a combination from both, the FBFNN has Input layer, hidden layer and output layer. The input layer receives input data into the network. Hidden layer is a fuzzy basis function which transfers input data into a membership function by using the Gaussian function. The output layer is linear combination for the hidden layer output.

We use two input layer node, 25 hidden nodes and one output layer nodes. The input value  $x_{Rotor}(k)$ ,  $i_u(k)$  as work

point are measurable in experiment. The value  $k_i$  and  $k_s$  for the work point are generated by LSM - Machine. For every logic rule, the Gaussian membership function shall be determined by the training function. Fig 9 is the FBFNN structure. The function of the nodes in each of the layers will be described.

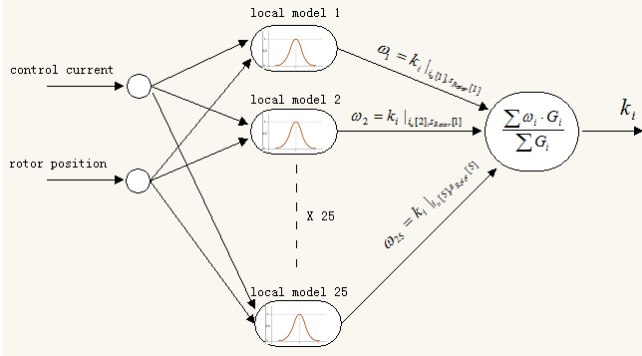

Fig 9: the structure of FBFNN

Layer 1: Input layer for input vector.

Layer 2: the nonlinear activation function of hidden layer is a Gaussian function which expressed as:

$$u_i = e^{-\frac{(\|\bar{x} - \bar{\tau}_i\|)^2}{2\sigma_i^2}}, \text{ with } i \in [1, n], \quad (32)$$

Where  $\tau_i$  is the Gauss function vertex for the  $i$ -th sub space (rule), which expresses the value  $i_u$  and  $x_{Rotor}$ . Parameter  $\sigma_i$  is the width (or variance) of the Gauss function.

Layer 3: the output of hidden layer is expressed as:

$$y = \sum_{i=1}^m w_i \cdot u_i / \sum_{i=1}^m u_i \quad (33)$$

Where  $w_i$  is the  $i$ -th weight between hidden layer nodes and output layer. The consequent parameters  $w_i$  for each sub model are from the process of parameter identification.

FBFNN algorithm uses the steepest gradient method to learn the weights in the network. The steepest gradient method is supervised learning which reduces the error between output and input of neural network. Detail will be found in [13].

As a result in this work, the width of the Gaussian membership function  $\sigma_i$  of every rule (sub space) will be optimal adapted as shown in Fig 10.

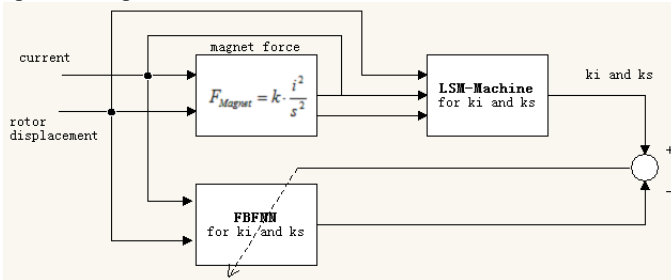

Fig 10: modulation for offline training of FBFNN

### Adaptive Kalman filter

In the majority of cases, a Kalman filter requires many system information for the prediction function. So an interesting problem is the possibility for the parameter adaptation in system state equation for a linear Kalman filter by using of the expert system, which is relative with system identification. Its aim is to enhance the prediction ability of the Kalman filter.

In this system, besides the constant parameter in state equation of the Kalman filter, the parameter  $k_i$  and  $k_s$  will be adapted. The combination of the Kalman filter and the expert system is known as "adaptive Kalman filter with using softcomputing". The system structure and diagram of the work are depicted in Fig 8.

### E. Simulation and result

In this section, the concept made in this work shall be verified by means of simulation and measurement. All relevant test rig parameters can be found in table.

Process noise variance	$8 \cdot 10^{-5} \text{ V}$
Measurement noise variance	$8.3 \cdot 10^{-5} \text{ V/mm}$
Rotor rotation	0/min

### Result of system identification

The identification of the magnet force and magnet parameter will be verified by means of a rotor position step response without force disturbance.

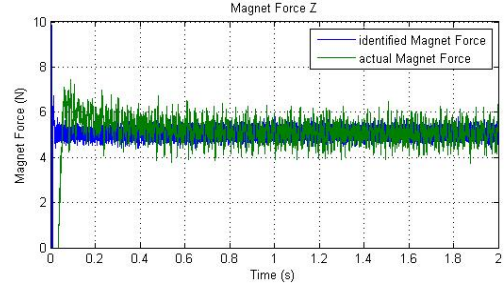

Fig 11: identified magnet force F

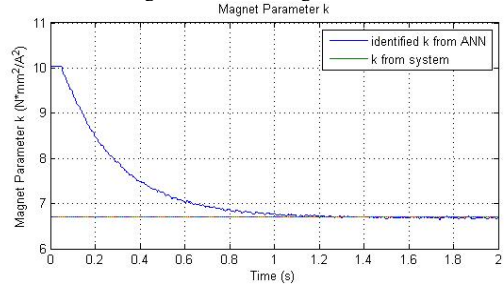

Fig 12: training result for magnet parameter  $k_{Magnet}$

After the identification of magnet parameter and the calculation of stiffness parameter by LSM-machine, inclusive offline training, the RBFN expert systems are generated. In this case, the calculated stiffness parameter from expert system will be compared with the constant stiffness parameter from traditional linearization. The difference between the two values will be illustrated.

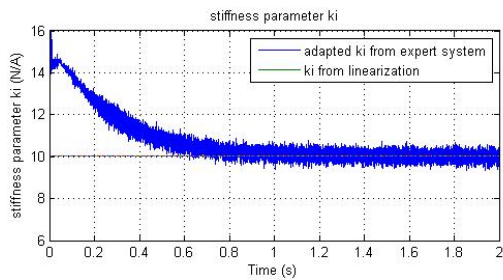

Fig 13: adapted  $k_i$  from fuzzy expert system

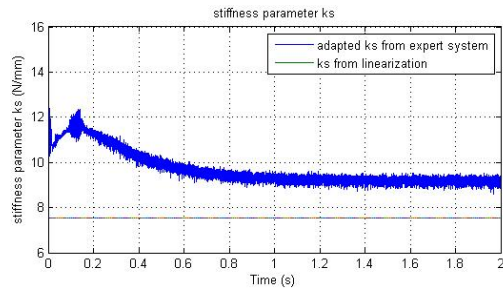

Fig 14: adapted  $k_s$  from fuzzy expert system

### Result of rotor displacement control

As a position control, the rotor displacement in step response is shown. In this case, the measured rotor displacement with and without measure noise, the estimated rotor displacement from Kalman filter will be illustrated, where a high correlation between the actual and the estimated position signal can be observed.

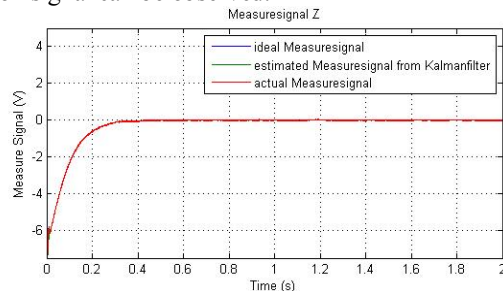

Fig 15: simulation result of the rotor displacement in step response

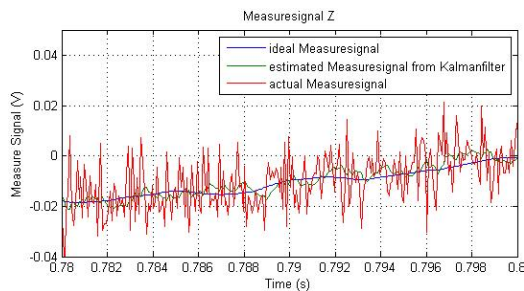

Fig 16: simulation result of the rotor displacement

### F. Conclusion

A new concept of Kalman filtering for AMB system has been introduced. To cope with the strong sensor noise and process noise, the Kalman filter is suggested to AMB system. It is based upon system identification which are realized by artificial neural network. Thus the system parameter and magnetic force can be identified online. Experiments have proved that the trained fuzzy expert system can give the actual

system parameter. The strong uncertainty and nonlinear of the system to the linear state equation in Kalman filter are reduced.

By estimating the magnet force, the ADALINE is used. By calculation of every sub-space, the LSM is suggested. All the calculation result will be saved in fuzzy system, which is optimal adjusted by RBFN. Results have shown, that the adapted linear state equation in Kalman filter is more reasonable.

An outlook has been given on more parameter estimation for state equation in Kalman filter, including noise variance. On principle, it is possible to reduce the estimation errors, and to realize a better state observation.

### REFERENCES

- [1]: H.Neumann, F.Worlitz, "Modellierung und Simulation eines Kalman-Filters für aktive Magnetlager", 8. Workshop Magnetlagerungstechnik Zittau-Chemnitz, Zittau, 2011
- [2]: Dapeng Wang, Fengxiang Wang, "design of PDC Controller based on T-S Fuzzy Model for Magnetic Bearing of Highspeed Motors", school of electric engineering shenyang university of technology, IEEE, 2010
- [3]: Z.C.Yu, D.Wen, H.Y.Zhang, "the identification model of magnetic bearing supporting system, IEEE,2008"
- [4]: Dipl. Martin Ruskowski, „ Aufbau und Regelung aktiver Magnetführungen, Fachgebiet Maschinenbau, Universität Hannover“, Dissertation, von 2004
- [5]: Thomas Schuhmann, Wilfried Hoffmann, Ralf Werner, "improving operational performance of active magnetic bearings using Kalman filter and state feedback control", IEEE transaction on industrial electronics, 2011.
- [6]: Marcin Kaminski, Teresa Orłowska-Kowalska, "Adaline-based Speed Controller of the Drive System with Elastic Joint", IEEE, 2012
- [7]: Wenle Zhang, "A Generalized ADALINE Neural Network for System Identification", IEEE International Conference on Control and Automation,2007
- [8]: Praveen Kumar Agarwal and Satish Chand, "Fuzzy logic control of four-pole Active Magnetic Bearing system",Proceedings of the 2010 International Conference on Modelling, Identification and Control, Okayama, Japan
- [9]: Safanah M.Raafat, Rini Akmelawati, "intelligent estimation of uncertainty bounds of an active magnetic bearings using ANFIS", IEEE,2011
- [10]: Thomas Schuhmann, Wilfried Hoffmann, Ralf Werner, "sensor integration and state estimation on magnetically levitated rotors", SPEEDAM 2006, IEEE, 2006
- [11]: M Mendel, "fuzzy logic systems for engineering: a tutorial", proceedings of IEEE, 1995
- [12]: Sung-Kyung Hong and Reza Langari, "robust fuzzy control of a magnetic bearing system subject to harmonic disturbances", IEEE transactions on control systems technology, 2000
- [13]: Huann-Keng Chiang, Chao-Ting Chu and Yong-Tang Jhou, "Fuzzy Control with fuzzy basis function neural network in magnetic bearing system", IEEE