

53. IWK

Internationales Wissenschaftliches Kolloquium
International Scientific Colloquium



Faculty of
Mechanical Engineering



PROSPECTS IN MECHANICAL ENGINEERING

8 - 12 September 2008

www.tu-ilmenau.de

th
TECHNISCHE UNIVERSITÄT
ILMENAU

Home / Index:

<http://www.db-thueringen.de/servlets/DocumentServlet?id=17534>

Published by Impressum

Publisher
Herausgeber Der Rektor der Technischen Universität Ilmenau
Univ.-Prof. Dr. rer. nat. habil. Dr. h. c. Prof. h. c. Peter Scharff

Editor
Redaktion Referat Marketing und Studentische Angelegenheiten
Andrea Schneider

Fakultät für Maschinenbau
Univ.-Prof. Dr.-Ing. habil. Peter Kurz,
Univ.-Prof. Dr.-Ing. habil. Rainer Grünwald,
Univ.-Prof. Dr.-Ing. habil. Prof. h. c. Dr. h. c. mult. Gerd Jäger,
Dr.-Ing Beate Schlütter,
Dipl.-Ing. Silke Stauche

Editorial Deadline
Redaktionsschluss 17. August 2008

Publishing House
Verlag Verlag ISLE, Betriebsstätte des ISLE e.V.
Werner-von-Siemens-Str. 16, 98693 Ilmenau

CD-ROM-Version:

Implementation
Realisierung Technische Universität Ilmenau
Christian Weigel, Helge Drumm

Production
Herstellung CDA Datenträger Albrechts GmbH, 98529 Suhl/Albrechts

ISBN: 978-3-938843-40-6 (CD-ROM-Version)

Online-Version:

Implementation
Realisierung Universitätsbibliothek Ilmenau
[ilmedia](#)
Postfach 10 05 65
98684 Ilmenau

© Technische Universität Ilmenau (Thür.) 2008

The content of the CD-ROM and online-documents are copyright protected by law.
Der Inhalt der CD-ROM und die Online-Dokumente sind urheberrechtlich geschützt.

Home / Index:

<http://www.db-thueringen.de/servlets/DocumentServlet?id=17534>

C. Gembus / M. Lotz / E. C. N. Silva / R. Theska

Topology Optimization of a Tetrahedron Mirror for a High-Precision Measuring and Positioning Machine

Abstract

A new 3D measuring concept for the nano measuring machine “NPM” of the Technical University of Ilmenau (Germany) uses a tetrahedron mirror made of Zerodur[®] as a measuring reference as well as plane table for the measuring object. The position of the plane table and of the object situated on it can be measured by interferometers in dimensions of nanometers. For improving the dynamical properties of the design, the weight of the mirror shall be optimized. Therefore, the commercial finite element method (FEM) software ANSYS[™] is applied for simulating the static and dynamic mirror properties. A topology optimization (TO) algorithm in the ANSYS[™] Parametric Design Language (APDL) is used as optimization method. This algorithm is extended to include manufacturing constraints, taking into account the manufacturing procedures of Zerodur[®] structures. The different optimization results are imported into the commercial CAD-software SolidWorks for building up the final CAD-models. Consequently, these different mirror designs are analyzed in ANSYS[™] to verify the required properties. This paper presents the results of the applied methods and shows that it is quite possible to run topology optimization algorithms with manufacturing constraints in APDL.

Introduction

Micro- and nanotechnology are very important for various different research fields of current and future science. The progress in these areas depends on the ability of measuring and positioning in dimensions of nanometers. In the special research field SFB 622 “Nanopositioning- and Nanomeasuring Machines” [5] funded by the German Research Foundation (DFG), scientists of 16 different scientific fields are working closely together to develop scientific fundamentals for the upcoming need of those machines with accuracies in the nanometer range and working areas of up to 450 mm by 450 mm by 80 mm at the “Technische Universität Ilmenau”. This paper is related to this research field and has been realized within the research cooperation between the Technical

University of Ilmenau (Germany) and the University of São Paulo (Brazil).

A new 3D interferometer-measuring concept of the NPM (as shown in Figure 1) uses a tetrahedron mirror as measuring reference as well as plane table. Therefore, the interferometric laser beams are reflected by the mirror planes, which are aluminum coated surface areas of the tetrahedron structure.

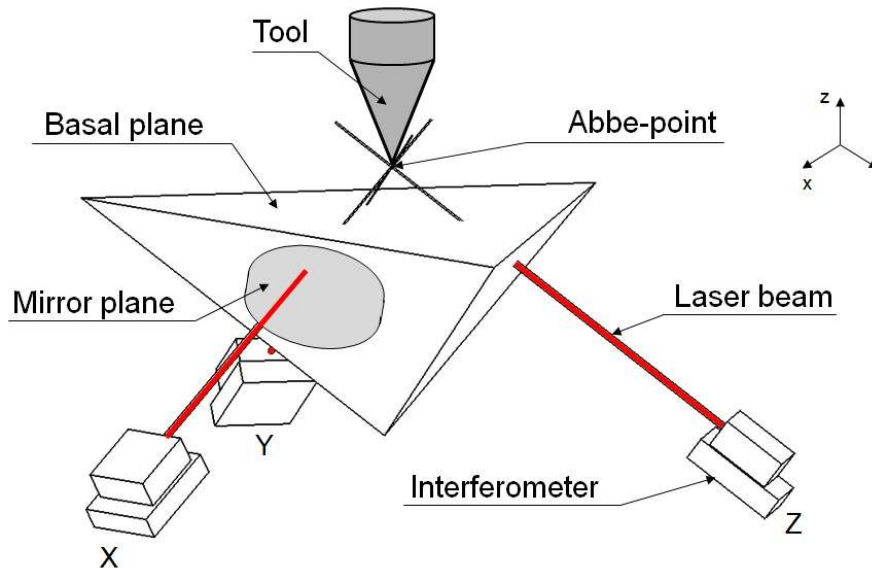

Figure 1: New interferometer arrangement with tetrahedron mirror support

The mirror support material is Zerodur[®], a glass ceramic, due to its low CTE (thermal expansion coefficient) and the resulting advantages for high-precision devices. The edge size of the mirror is about 600 mm, which results in a total weight of about 35 kg. Since the weight of the mirror influences the dynamical properties of the measuring system, its weight reduction provides great potential to improve the measuring machine.

Topology Optimization Theory

The topology optimization (TO) is applied as an optimization method for reducing the volume and consequently the mass of the mirror. The TO is a systematic and efficient numerical method for designing optimal structures in engineering. It combines the finite element method (FEM) with mathematical optimization algorithms. During several iterations, the optimization algorithm assigns a pseudo-density value to each of the elements within the predefined design domain. A pseudo-density of zero means no material and a density of one means full material.

In this work, the APDL (ANSYS™ parametric design language) algorithm from Lopes [2] was enhanced and adapted to the existing optimization problem. This algorithm is able to solve topology optimization problems considering only gravity and inertial forces using the optimality criteria [3], the SIMP (Simple Isotropic Material with Penalization) method [3] and the continuation method [3]. It maximizes the stiffness of the structure regarding a defined volume reduction. Figure 2 shows a simple TO example for a twice-supported beam using the algorithm of Lopes.

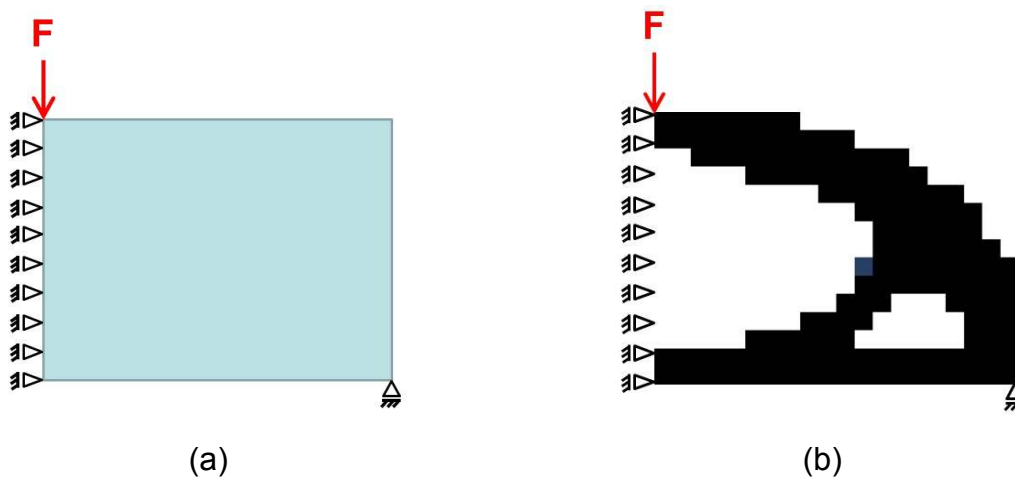

Figure 2: Topology Optimization of a 2D beam, a) design domain with boundary conditions, b) optimization result

As the mirror will be made of Zerodur®, the typical machining procedures for Zerodur® structures have to be considered while designing the mirror. The tools, machines and processes, which are used in the machining procedure of Zerodur®, are equal to the processes applied to optical glass. This means, that it is possible to grind, lap and polish Zerodur® as well as drill through holes and blind holes. Even filigree structures can be built without problems by grinding, ultrasonic drilling or water jet cutting.

Optimal structures obtained by TO are typically complex and it is quite difficult to machine such complex monolithic structures with the machining processes for Zerodur®, especially the machining of large undercuts is critical. The split of the structure into pieces would allow the machining itself but its assembly would include many difficulties, due to the special properties of Zerodur®. Furthermore, the recombined structure would have disadvantages concerning the required precision for an application in the NPM.

A possibility to solve this problem is to add various manufacturing constraints to TO, so that the optimization takes into account different machining processes [4]. Therefore, the TO algorithm of Lopes [2] was enhanced by implementing casting constraints. These constraints have been chosen because they avoid undercuts in one direction. This guarantees the accessibility of all regions, where material needs to be machined by the drilling or grinding tool. In the following, the way casting constraints work is explained through a simple 2D beam example. The used design domain is shown in Figure 2a.

The material distribution after the first TO iteration without casting constraints is illustrated in Figure 3a. The color scale, which assigns the pseudo-density value between zero and one to different shades of blue, can be seen in Figure 3g.

Applying the casting constraint enhancement, during the calculation of the optimal material distribution, the pseudo-densities of all neighboring elements in a horizontal line are compared, starting on the left side of the design domain. By assigning the higher pseudo-density of two horizontal neighboring elements to the right one, the decrease of the pseudo density from the left to the right side is prohibited. The material distribution after the first iteration can be seen in Figure 3b. This leads to a material concentration on the right side of the design domain (Figure 3c), which does not contain undercuts in horizontal direction.

In a second TO run with the same boundary conditions, the pseudo-densities of all horizontal neighboring elements are compared again, starting on the right side of the design domain. This time, the higher pseudo-density is assigned to the left one of two horizontal neighboring elements, which leads to a material concentration on the left side of the design domain (Figure 3d and Figure 3e).

The final structure (Figure 3f) is the intersection of the elements with full material (pseudo-density = 0.75 to 1) of the structures in Figure 3c and Figure 3e.

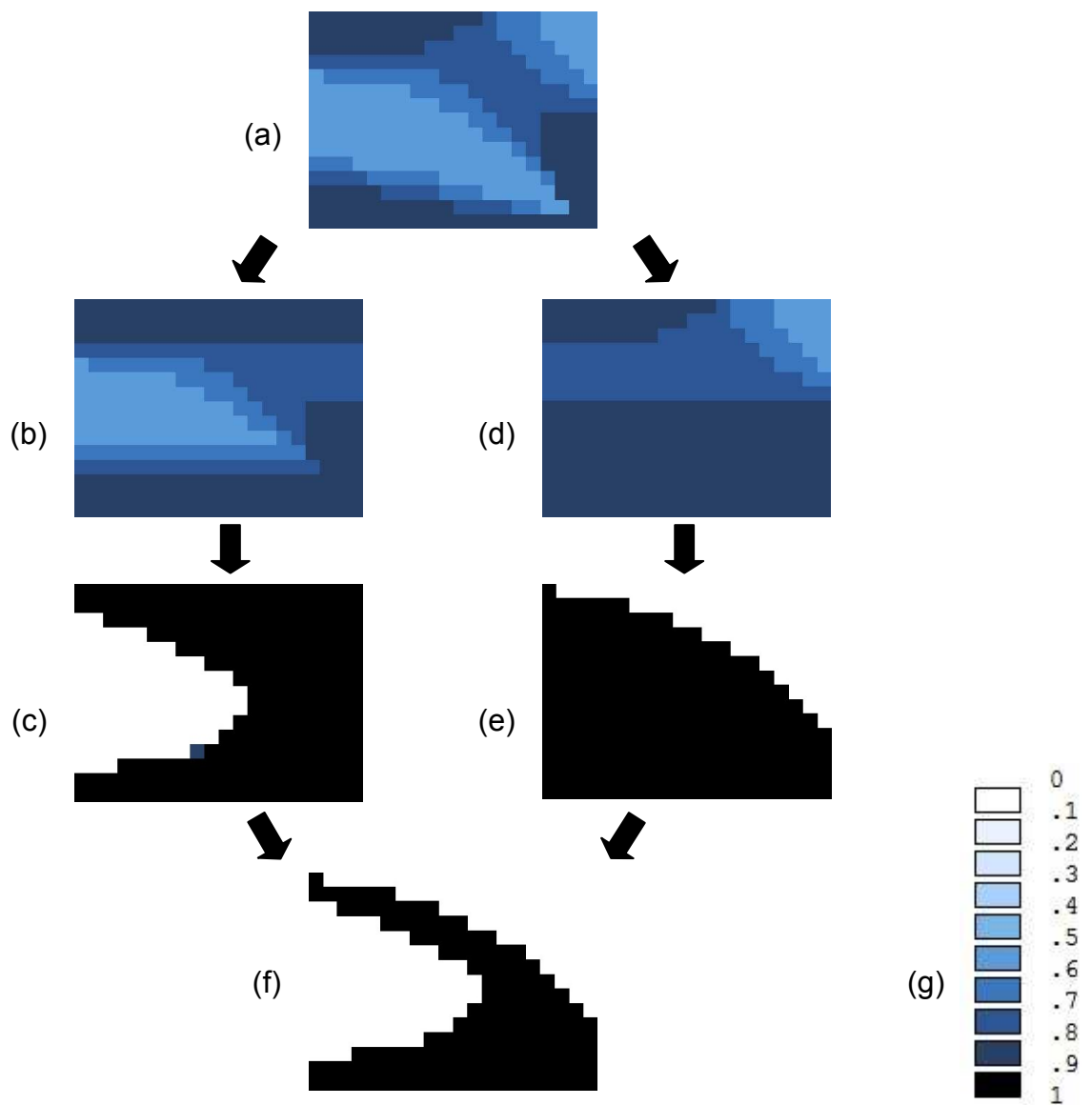

Figure 3: 2D TO with casting constraints, a) material distribution after 1st iteration, b) material distribution after 1st iteration with material concentrated on right side, c) final material distribution with material concentrated on right side, d) material distribution after 1st iteration with material concentrated on left side, e) final material distribution with material concentrated on left side, f) TO result (intersection of c) and e)), g) color scale for pseudo-density values

Numerical Implementation

In order to build up an adequate solid model of the mirror and its boundary conditions in ANSYS™, the mirror and the v-grooves, which connect the mirror with the framework, are modeled using the CERIG-command. This APDL command creates a stiff region between the nodes at the model surface next to the support points and a defined node below the model (center of the ball). Constraining the possible movements of the node, which models the center of the ball, a ball/v-groove arrangement can be simulated adequately.

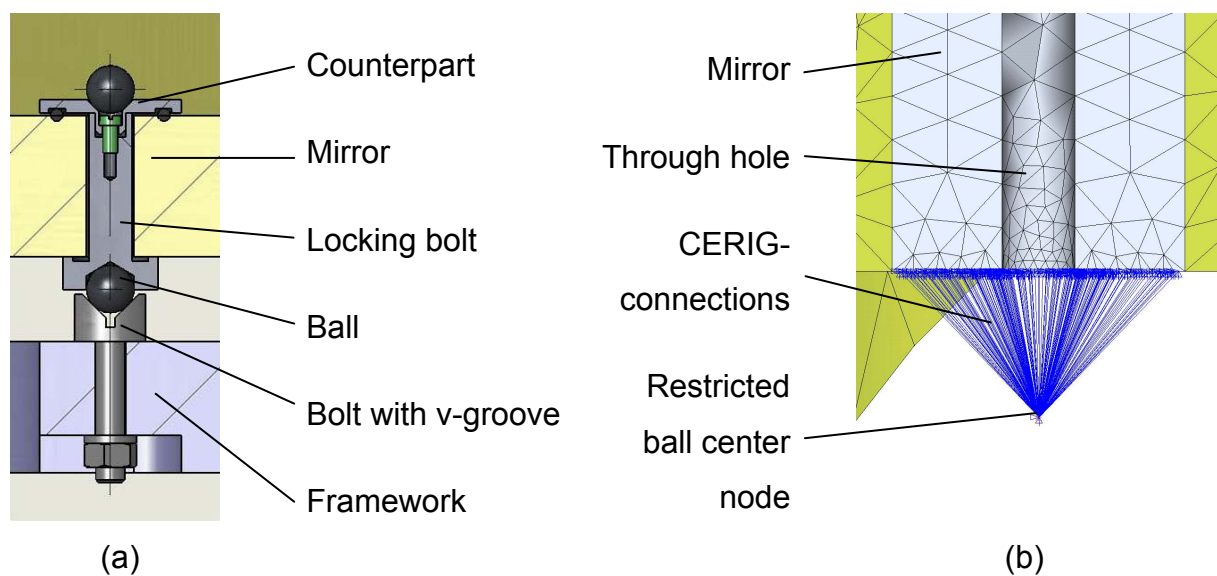

Figure 4: Ball/v-groove arrangement: a) sketched, b) as finite element model.

If the model and its boundary conditions are symmetric, the model can be reduced to the repetitive part in order to save calculation time and computational power. In this way, the model is reduced to one sixth of its original size.

To achieve an optimization result, which is easier to post-process, a finite element (FE) model consisting of regular hexahedrons is built up. These hexahedrons form regular columns and slices so that each element can be addressed easily with numerical algorithms. This regular meshed FE model is also necessary for applying the additional casting constraints. Figure 5 presents the results of a TO with 60 % volume reduction with an irregular mesh consisting of tetrahedrons (100,000 elements, Figure 5a) and a regular mesh consisting of cubes (90,000 elements, Figure 5b). The element type used in these models is SOLID95.

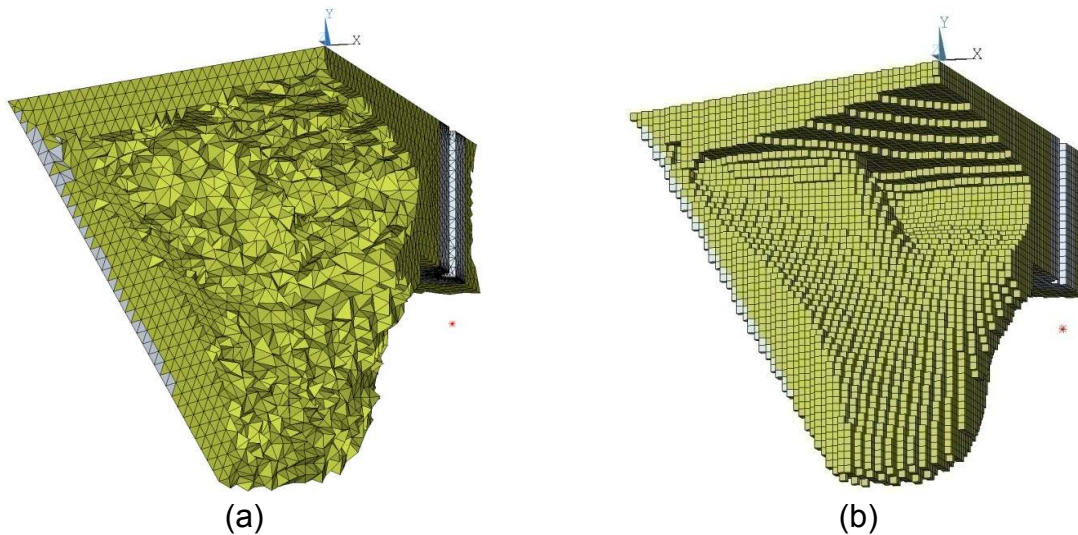

Figure 5: Isometric view of TO result: a) with irregular tetrahedron mesh, b) with regular hexahedron mesh

Since this optimization result is the optimal material distribution for one sixth of the mirror, an assembling of this mirror fraction is necessary, resulting in a full mirror structure with complex shapes and undercuts. Therefore, in another TO, casting constraints are applied in order to avoid undercuts in vertical direction. The result of the TO with a volume reduction of 60 % and without casting constraints is shown in Figure 6a. Figure 6b presents the result of the TO including casting constraints, which does not contain undercuts. The TO algorithm distributes the material so that the structure possesses vertical ribs.

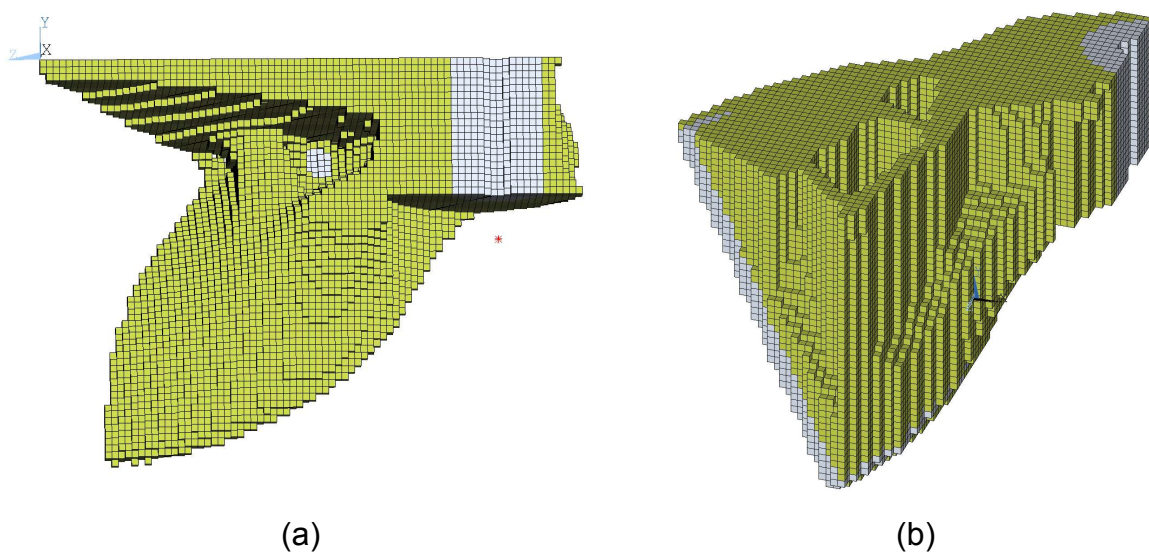

Figure 6: Isometric view of TO result: a) without any manufacturing constraints, b) with casting constraints

Results

In this work, the topology optimization of a tetrahedron shaped mirror support subjected to inertial forces, such as gravity, is studied. In all simulations, the properties of the isotropic material Zerodur[®] are:

- Young's modulus = 90.3 GPa
- Poisson's ratio = 0.243
- Material density = 2.53 g/cm³

The applied load for the optimization is the gravity acceleration $g = 9.81 \text{ m/s}^2$.

As a result, Figure 7 illustrates the final mirror designs after the post-processing and the implementation of the numerically calculated design proposals in the CAD software SolidWorks. Figure 7a shows the mirror design generated with the TO without casting constraints. The structure is closed at the top, but it possesses a big cut-out at the bottom, where the dispensable material is machined. The generation of this CAD-model was quite difficult because the machining process had to be taken into account during the post-processing.

The final structure post-processed from the TO including casting constraints, which is a very detailed implementation of the calculated optimal material distribution, can be seen in Figure 7b. The post-processing of this design was easier because the TO already distributed the material in a suitable way for machining. While reaching a volume reduction of around 52 % (Figure 7a) and 58 % (Figure 7b), they fulfill the required conditions of maximum stress, minimum eigenfrequency and maximum displacement (deformation) perpendicular to the mirror planes.

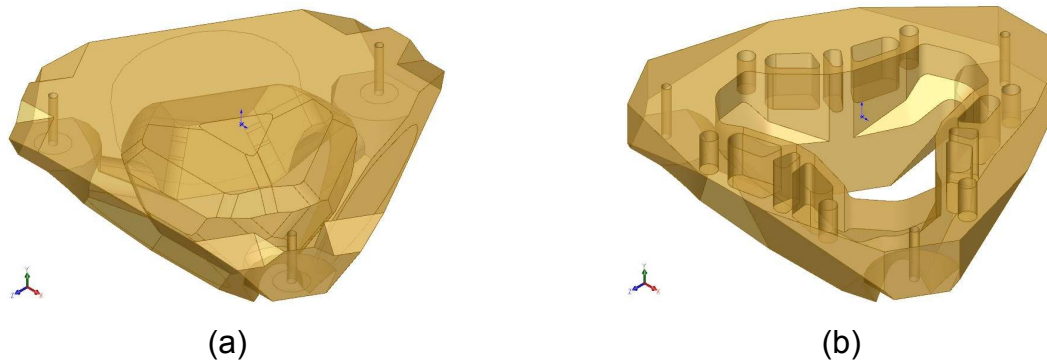

Figure 7: CAD-models of optimal designs: a) achieved by TO without any manufacturing constraints, b) achieved by TO with casting constraints.

Conclusion and Outlook

The topology optimization was applied within the commercial FEM user interface of ANSYS™ for designing optimal three-dimensional structures affected only by gravity (self-weight). Furthermore, using the APDL, casting constraints were implemented successfully, which contributes to simplify the post-processing. Finally, the optimal mirror design was converted into a solid model. The result is a mirror design, which is easier to manufacture with the available manufacturing procedures for Zerodur® structures. This work demonstrates a method, which optimizes the weight of the structure following given boundary conditions. It also supports the engineer generating the part by usage of state of the art optical manufacturing technology.

In future works, the implementation of manufacturing technologies such as multi-axis-machining can be optimized by the usage of the existing casting constraints in more than one direction. Furthermore, there is a high potential in the development of more specific constraints biased by optical manufacturing technology and material-specific requirements.

References:

- [1] HAFTKA, R. T.; GÜRDAL, Z.: *Elements of Structural Optimization*. Dordrecht: Kluwer Academic Publishers, 1999
- [2] LOPES, R. A.: *Otimização Topológica Aplicada Ao Projeto De Estruturas Submetidas A Forças De Campo Mecânicas*. São Paulo: Universidade de São Paulo, Diss. de Mestrado, 2005
- [3] BENDSØE, M. P.; SIGMUND, O.: *Topology Optimization - Theory, Methods and Applications*. Berlin: Springer-Verlag, 2003/2004
- [4] LIPPI, T. N.: *Restrições de Manufatura Aplicadas ao Método de Otimização Topológica*. São Paulo: Universidade de São Paulo, Diss. de Mestrado, 2008
- [5] <http://www4.tu-ilmenau.de/sfb622/>

Authors:

Christian Gembus¹
Dipl.-Ing. Markus Lotz¹
Prof. Dr.-Ing. Emílio Carlos Nelli Silva²
Univ.-Prof. Dr.-Ing. René Theska¹

¹ Technische Universität Ilmenau
Department of Mechanical Engineering
Precision Engineering
P.O.B. 10 05 65
98684 Ilmenau, Germany
Phone: (0049) 0 3677 / 69-3822
Fax: (0049) 0 3677 / 69-3823
E-mail: rene.theska@tu-ilmenau.de

² Universidade de São Paulo
Department of Mechatronics and
Mechanical Systems Engineering
Av. Prof. Mello Moraes 2231
05508-900, São Paulo, SP, Brazil
Phone: (0055) 0 11 / 3091-5337
Fax: (0055) 0 11 / 3091-5461
E-mail: ecnsilva@usp.br