

## 50. Internationales Wissenschaftliches Kolloquium

September, 19-23, 2005

### Maschinenbau von Makro bis Nano / Mechanical Engineering from Macro to Nano

Proceedings

Fakultät für Maschinenbau /  
Faculty of Mechanical Engineering

Startseite / Index:

<http://www.db-thueringen.de/servlets/DocumentServlet?id=15745>

## Impressum

- Herausgeber: Der Rektor der Technischen Universität Ilmenau  
Univ.-Prof. Dr. rer. nat. habil. Peter Scharff
- Redaktion: Referat Marketing und Studentische Angelegenheiten  
Andrea Schneider
- Fakultät für Maschinenbau  
Univ.-Prof. Dr.-Ing. habil. Peter Kurtz,  
Univ.-Prof. Dipl.-Ing. Dr. med. (habil.) Hartmut Witte,  
Univ.-Prof. Dr.-Ing. habil. Gerhard Linß,  
Dr.-Ing. Beate Schlütter, Dipl.-Biol. Danja Voges,  
Dipl.-Ing. Jörg Mämpel, Dipl.-Ing. Susanne Töpfer,  
Dipl.-Ing. Silke Stauche
- Redaktionsschluss: 31. August 2005  
(CD-Rom-Ausgabe)
- Technische Realisierung: Institut für Medientechnik an der TU Ilmenau  
(CD-Rom-Ausgabe) Dipl.-Ing. Christian Weigel  
Dipl.-Ing. Helge Drumm  
Dipl.-Ing. Marco Albrecht
- Technische Realisierung: Universitätsbibliothek Ilmenau  
(Online-Ausgabe) [ilmedia](#)  
Postfach 10 05 65  
98684 Ilmenau
- Verlag:  Verlag ISLE, Betriebsstätte des ISLE e.V.  
Werner-von-Siemens-Str. 16  
98693 Ilmenau

© Technische Universität Ilmenau (Thür.) 2005

Diese Publikationen und alle in ihr enthaltenen Beiträge und Abbildungen sind urheberrechtlich geschützt.

ISBN (Druckausgabe): 3-932633-98-9 (978-3-932633-98-0)  
ISBN (CD-Rom-Ausgabe): 3-932633-99-7 (978-3-932633-99-7)

Startseite / Index:

<http://www.db-thueringen.de/servlets/DocumentServlet?id=15745>

**M. Marinov / I. Topalov / T. Djamiykov / S. Hecht**

## **Intelligent Sensor Node for Building Monitoring and Control Applications**

### **ABSTRACT**

Sensor networks have come a long way since the first point-to-point analog system. Tomorrow's networks will not be dominated by only one architecture, but will integrate a variety of networking schemes.

We are primarily focusing on the usage of the IEEE 1451.3 Standard for building Distributed Multidrop Systems. This paper presents an approach to make an Intelligent Sensor Node for Building Monitoring and Control Applications. The basic structure of the sensor node, the ways of connecting the intelligent sensor nodes to a network and the communication over Internet are presented. Integrated sensors with digital and analog output are used for accurate readings of temperature, humidity, barometric pressure, light intensity and other environmental parameters.

### **1 INTRODUCTION**

The proliferation of sensor and instrument busses has introduced new ways to interface and communicate with transducers. The widespread availability of microelectronics, computers, and networks provide a good opportunity to connect large arrays of sensors to measure, characterize, model, and monitor many large structures, machinery, and mechanical systems. Nevertheless, these new ways have been useful only to segments of the transducer community. In addition, the increased use of large number of transducers has also created a need for keeping track of the transducers and their associated manufacturer data. The availability of economical off-the-shelf memory chips has helped to implement built-in electronic data sheets in small transducers. This has significant contribution in building smart transducers with self-identification capability through the use of electronic data sheets. The transducer community also recognized the need for a common way of connecting these smart transducers and thus began the work on the IEEE 1451 Smart Transducer Interface Standard.

The IEEE 1451 provides a set of common interfaces for connecting transducers (sensors and actuators) to existing instrumentation and control networks and lays a path for the sensor community to design systems for future growth. It is intended to provide an easy upgrade path

for connectivity of products from any manufacturer of transducers or networks. The IEEE 1451 Standard can be basically viewed as software and hardware oriented interfaces. The software portion is an information model defining the behaviors of a smart transducer using object model approach and the path for network connectivity. This work has been completed and become the IEEE 1451.1-1999 Standard [1]. The sensor usage crosses various industries therefore the hardware portion of the IEEE 1451 Standard is divided into 1451.2, 1451.3, and 1451.4 to meet their specific needs. The first one, focused on an interface for transducers with lower signal bandwidth requirements, has been completed and designated as the IEEE 1451.2 Standard [2].

The IEEE 1451.4 Working Group is charged to define a universally accepted, mixed-mode transducer interface standard (i.e. able to work both in analog signal transmission mode and in digital communication mode, but not simultaneously). The initial focus was on 2-wires piezoelectric accelerometers, however, generic transducers such as strain gauge, thermal couples, RTD, are going to be included.

We are primarily focusing on the usage of the IEEE 1451.3 Standard for building Distributed Multidrop Systems.

## **2 IEEE 1451.3**

The proposed IEEE 1451.3, a Smart Transducer Interface for Sensors and Actuators - Digital Communication and Transducer Electronic Data Sheet (TEDS) Formats for Distributed Multidrop Systems is proposed to utilize spread-spectrum modulation techniques to allow the following functions to be performed over a single cable:

1. Synchronizing data acquisition for an array of sensors and communicating simultaneously with an array of transducer bus interface modules (TBIM);
2. Providing power for operation of all transducers on the bus and their associated electronics;
3. Proposing a standard digital interface (TBIM) which can connect multiple physically separated transducers in a multidrop configuration;
4. Using in applications where transducers are distributed across an area in which it is not feasible to install an NCAP for each transducer channel;

Main specific components in the network are:

1. Transducer Bus Controller (TBC): One on each NCAP to communicate with multiple TBIMs. Supports multiple, time-synchronized data channels to occupy single transmission medium (bus);
2. Transducer Bus Interface Module (TBIM): A transducer node, like the STIM, but communicates with NCAP through multi-drop transducer bus and TBC;

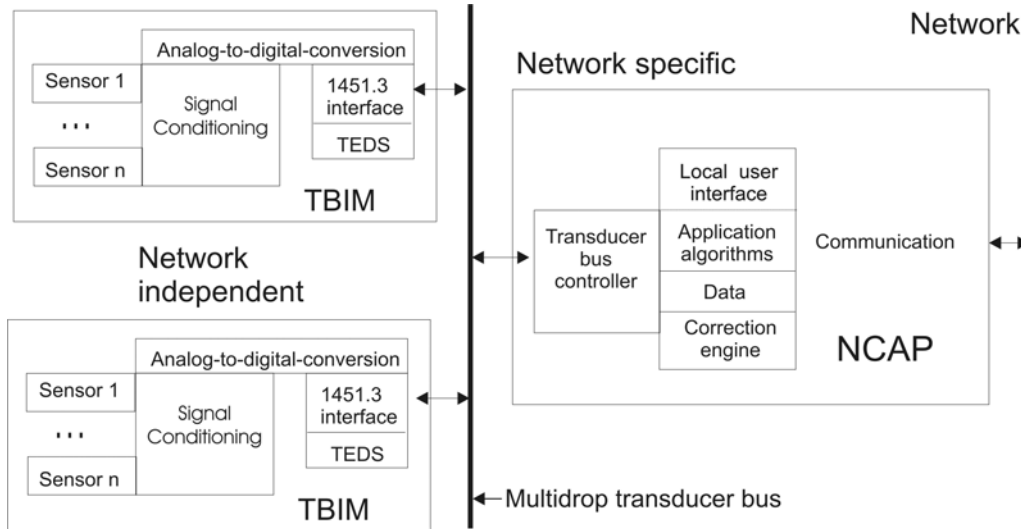

Fig. 1. Implementation of the IEEE 1451.3 general model

This standard is used for complex data acquisition systems employing a large number of sensors and actuators distributed over a limited area and where it is not practical to run the control network or field bus cables to each transducer site.

### 3 TBC BASED ON 1-WIRE MASTER NODE AND TBIM BASED ON 1-WIRE SENSOR AND ACTUATOR SLAVE NODES FOR BUILDING MONITORING AND CONTROL APPLICATIONS

In case of building and factory controls, the systems are very large and the sensor infrastructure is very expensive. Intelligent sensors not only provide significant savings due to the reduction in calibration and monitoring equipment costs, they also provide better reliability and safety because local control is maintained by the sensor even if the facility-wide control network fails [3].

The 1-Wire net, sometimes known as a MicroLAN, is a low cost bus based on a PC or microcontroller (in our case this is TBC) communicating digitally over twisted pair cable with 1-Wire components (these are the TBIMs). The network is defined with an open drain (wired-AND) master/slave multidrop architecture that uses a resistor pull-up to a nominal 5V supply at the master [4]. A 1-Wire net based system consists of three main elements: a bus master (TBC) with controlling software, the wiring and associated connectors and 1-Wire devices (TBIMs). The 1-Wire net allows tight control because no node is allowed to speak unless requested by the master, and no communication is allowed between slaves, except through the master. Typical communication over 1-Wire is shown on Fig. 2.

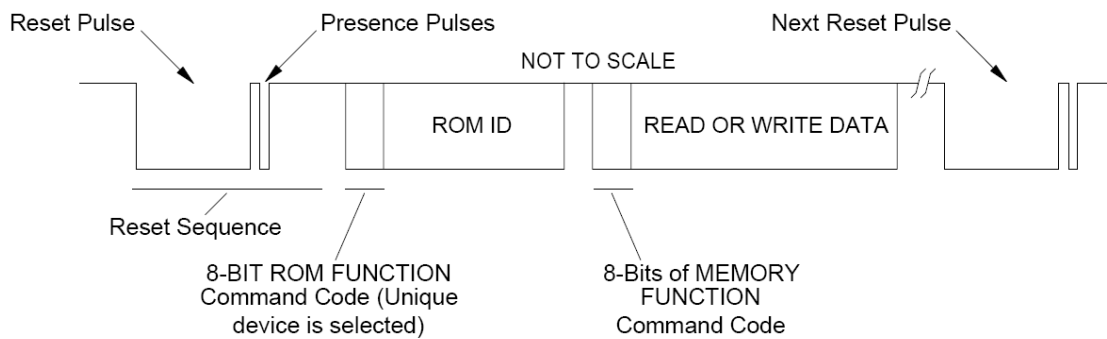

Fig. 2. A typical 1-Wire communication sequence

1-Wire net protocol uses conventional CMOS/TTL logic levels, where 0.8V or less indicates a logic zero and 2.2V or greater represents a logic one. Operation is specified over a supply voltage range of 2.8 to 6 volts. Both the master and slaves are configured as transceivers allowing data to flow in either direction, but only one direction at a time. Technically speaking, data transfers are half-duplex and bit sequential over a single pair of wires, data and return, from which the slaves “steal” power by use of an internal diode and capacitor [5]. Data is read and written least significant bit first. Regarding physical layer, readily available, low capacitance, unshielded, Category 5 twisted pair phone wire is recommended for the bus.

Data on the 1-Wire net is transferred with respect to time slots. For example, to write a logic one to a 1-Wire device, the master pulls the bus low and holds it for 15 microseconds or less. To write a logic zero, the master pulls the bus low and holds it for at least 60 microseconds to provide timing margin for worse case conditions. A system clock is not required, as each 1-Wire part is self clocked by its own internal oscillator that is synchronized to the falling edge of the master. Power for chip operation is derived from the bus during idle communication periods when the DATA line is at 5V by including a half wave rectifier onboard each slave.

Having all this in mind, we developed the customized 1451.3 general model to the needs for the 1-Wire interface. This is drawn on Fig. 3. As we look closer in the figure, we might see the existence of all the major building blocks of the 1451.3 standard compared to Fig. 1. The interesting part here comes with the slave nodes. The 1-Wire slave node consists all the blocks in one single case – this means that the whole sensor or actuator is made of one single integrated circuit. There are of course exclusions to this statement, but most of the sensors incorporate, first of all, the sensing or input/output element, the analog to digital converter and the signal conditioning, and the 1-Wire interface circuits. What is extra to this sensor is its unique serial code, or each 1-Wire slave node is hard coded with a world wide unique 64 bits serial number.

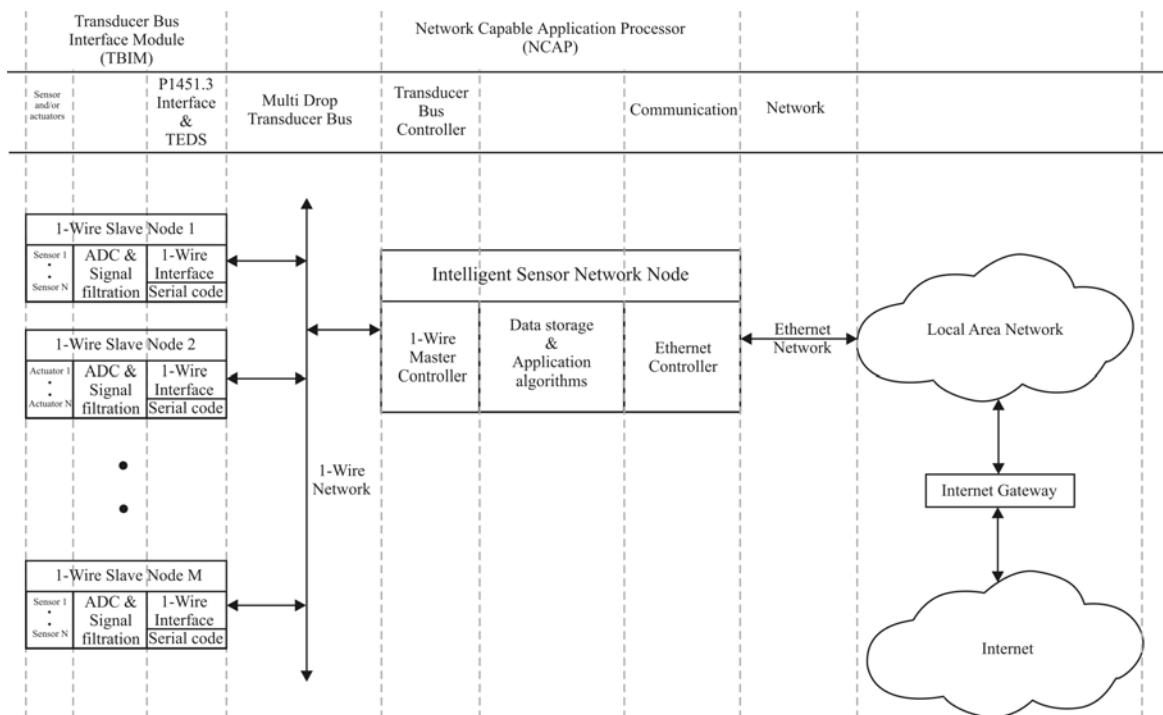

Fig. 3. The structure of the intelligent sensor node and its communication.

Special attention is paid to the Transducer Electronic Data Sheet (TEDS). TEDS is what distinguishes the simple sensors and actuators from the intelligent ones. The mandatory data for each TEDS are the manufacturing ID, version number, serial number, etc. These mandatory fields correspond to the 1-Wire slave node unique serial ID. In this ID is written the information of the manufacturer, serial number, and ID of the 1-Wire node. The other optional data for TEDS is skipped in some 1-Wire slave nodes. TEDS description is written in TEDS template. Description of all the fields is placed in the template, their position and size. For some temperature 1-Wire sensors, the optional fields for the TEDS are skipped, because the ID of the sensor points to an ID of a template, describing the accuracy, resolution and other parameter of the given type of sensor. This is a simple version of the TEDS. In case of requirements for more complex and descriptive TEDS template, along the 1-Wire temperature sensor is connected another 1-Wire node (1-Wire EEPROM) keeping all the TEDS data. The NCAP module connects to a local area network based on Ethernet. In case of needs of Internet monitoring and control an internet gateway is placed which gives connectivity the World Wide Web [6].

After the 1451 standard is embedded in our solution, comes time for a couple of examples showing particular use of these 1-Wire slave devices as TBIMs. We start with Fig. 4

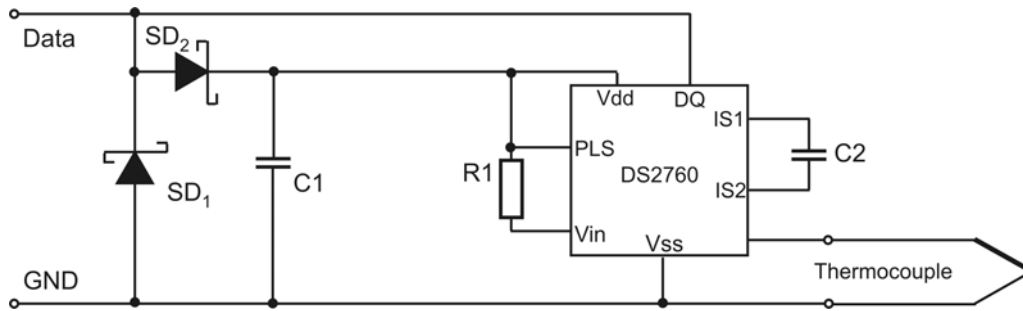

Fig. 4. Using a DS2760 to read a thermocouple on the 1-Wire net.

The schematic in the figure illustrates both the simplicity and ease with which a DS2760 can be used to convert a standard thermocouple into a smart sensor with multi-drop capability. In the circuit, C1 and one of the Schottky diodes in CR1 form a half wave rectifier that provides power for the DS2760 by ‘stealing’ it from the bus during idle communication periods when the bus is at 5V. This is a discrete implementation of the parasite power technique used internally by 1-Wire devices to provide their own operating power. The remaining Schottky diode in the package is connected across DATA and GND and provides circuit protection by restricting signal excursions that go below ground to about minus four tenths of a volt. Under bus master control, DS2760 monitors the voltage developed between the hot and cold junctions of the thermocouple as well as measuring the temperature of the cold junction with its internal temperature sensor. The master uses this information to calculate the actual temperature at the hot junction of the TC. In addition to the function it provides, DS2760 has also 32 bytes of EEPROM, which are ideal memory to fit the 1451 Standard requirements for a TEDS table.

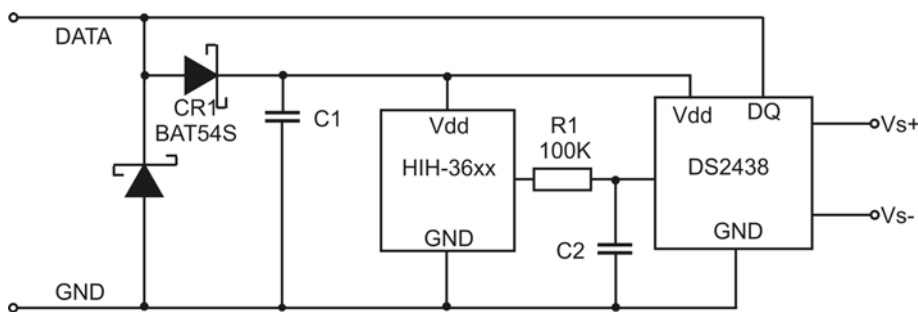

Fig. 5. A humidity sensor using the DS2438.

Humidity is an important factor in many manufacturing operations as well as affecting personal comfort. With the proper sensing element, it can be measured over the 1-Wire net. The Honeywell sensing element specified here develops a linear voltage versus relative humidity (RH) output that is ratiometric to supply voltage. That is, when the supply voltage varies, the sensor output voltage follows in direct proportion. This requires that the voltage across the



sensor element as well as its output voltage be measured. In addition, calculation of True RH requires knowledge of the temperature at the sensing element. Because it contains all the necessary measurement functions to do the calculations, the DS2438 makes an ideal choice to construct a humidity sensor. In Fig. 5, the analog output of the HIH-3610 humidity sensing element is converted to digital by the main ADC input of a DS2438. In operation, the bus master first has the DS2438, report the supply voltage level on its Vdd pin, which is also the supply voltage for HIH-3610, the sensing element. Next, the master has DS2438 read the output voltage of humidity sensor and report local temperature from its on-chip sensor. Finally, the master calculates true relative humidity from the three parameters supplied by DS2438. And not forgetting the 40 bytes of EEPROM which help us build the TEDS table and thus it realizes the “Plug & Play” feature of the smart sensors.

The examples in Fig. 4 and Fig. 5 describe the use of 1-Wire slave nodes as sensing elements [7]. With the help of variety of other 1-Wire elements, including the one so called addressable switches, the actuators are made easy. A good example of 1-Wire dual addressable switch and 1 Kb of EEPROM is DS2406.

#### 4 CONCLUSION

Currently, transducer manufacturers, system integrators, network vendors, and users are facing an enormous problem of trying to support multi-vendor networks and bridge the smart transducer market across industries. In order to motivate the necessity of the IEEE P1451 standards effort, the relevant problems have been presented in this paper in detail. The reference implementation represents concrete examples of the Information Model from 1451.1 as well as the digital hardware interface implementation from 1451.3.

An additional benefit is that the standard will allow system integrators to upgrade the sensor networks, without having to change the actual transducers. So, not only the sensor manufacturers but also the system integrators will have more freedom from the details of the concrete bus implementation.

1-Wire technology made possible the combination of electronic communication and instrumentation. The simple reliable identification of the sensor nodes and the ability of self-powering give significant advantages for an effective building of distributed sensor networks.

The potential of the Internet-based data acquisition and control is big. Distant monitoring of processes and laboratory data are only a small piece of the applications which require Internet access. National Instruments is another monitoring and controlling provider which stands also behind the P1451 standard and already supports the standard in its product LabVIEW [8]. The

presented approach for Internet-based environmental data acquisition is successfully tested in low-cost systems for remote Building Monitoring and management of greenhouses. And when we look across the widely spread wired communication networks, no doubt, the eye is caught by Ethernet, which is also used in our development.

**References:**

- [1] IEEE Std 1451.1-1999, Standard for a Smart Transducer Interface for Sensors and Actuators - Network Capable Application Processor (NCAP) Information Model, Institute of Electrical and Electronics Engineers, Inc., Piscataway, New Jersey 08855, June 25, 1999.
- [2] IEEE Std 1451.2-1997, Standard for a Smart Transducer Interface for Sensors and Actuators - Transducer to Microprocessor Communication Protocols and Transducer Electronic Data Sheet (TEDS) Formats, Institute of Electrical and Electronics Engineers, Inc., Piscataway, New Jersey 08855, September 26, 1997.
- [3] Hill, J., R. Szewczyk, A. Woo, S. Hollar, D. Culler, and K. Pister. System architecture directions for networked sensors. In Proceedings of the 9th International Conference on Architectural Support for Programming Languages and Operating Systems ASPLOS-IX, pages 93–104, Cambridge MA, USA, November 2000.
- [4] Dallas Semiconductor. MicroLAN Design Guide, Sep. 2003.
- [5] Awtrey, D., Transmitting Data and Power over the 1-Wire Bus,” Sensors: 48-51, Feb. 1997.
- [6] Howarth, D.: Performing Data Acquisition over the Internet. Sensors Magazine, January 1998.
- [7] Awtrey, D., The 1-Wire Weather Station, Sensors: 34-40, June 1998.
- [8] National Instruments, LabVIEW Manual, 2001.

**Authors:**

Dr. M. Marinov, I. Topalov, Dr. T. Djamiykov,  
Technical University Sofia, Faculty of Electronics,  
P.O. Box 43, BG-1756 Sofia, Bulgaria, Tel.: +3592 965 3677, e-mail: mbm@tu-sofia.bg

Dr.-Ing. S. Hecht, Technical University of Ilmenau, Faculty of Mechanical Engineering,  
PF 100 565, D-98684 Ilmenau, Tel.: +49 3677 69 2479, e-mail: S.Hecht@mb.tu-ilmenau.de