

**54. IWK**  
Internationales Wissenschaftliches Kolloquium  
International Scientific Colloquium

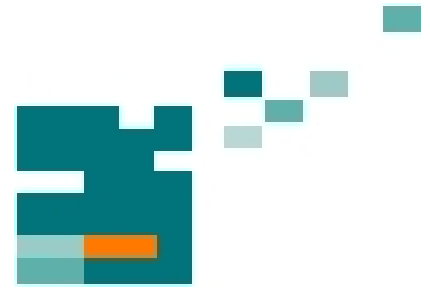

**Information Technology and Electrical  
Engineering - Devices and Systems, Materials  
and Technologies for the Future**



Faculty of Electrical Engineering and  
Information Technology

Startseite / Index:

<http://www.db-thueringen.de/servlets/DocumentServlet?id=14089>

## Impressum

Herausgeber: Der Rektor der Technischen Universität Ilmenau  
Univ.-Prof. Dr. rer. nat. habil. Dr. h. c. Prof. h. c.  
Peter Scharff

Redaktion: Referat Marketing  
Andrea Schneider

Fakultät für Elektrotechnik und Informationstechnik  
Univ.-Prof. Dr.-Ing. Frank Berger

Redaktionsschluss: 17. August 2009

Technische Realisierung (USB-Flash-Ausgabe):  
Institut für Medientechnik an der TU Ilmenau  
Dipl.-Ing. Christian Weigel  
Dipl.-Ing. Helge Drumm

Technische Realisierung (Online-Ausgabe):  
Universitätsbibliothek Ilmenau  
[ilmedia](#)  
Postfach 10 05 65  
98684 Ilmenau

Verlag:  Verlag ISLE, Betriebsstätte des ISLE e.V.  
Werner-von-Siemens-Str. 16  
98693 Ilmenau

© Technische Universität Ilmenau (Thür.) 2009

Diese Publikationen und alle in ihr enthaltenen Beiträge und Abbildungen sind urheberrechtlich geschützt.

ISBN (USB-Flash-Ausgabe): 978-3-938843-45-1  
ISBN (Druckausgabe der Kurzfassungen): 978-3-938843-44-4

Startseite / Index:  
<http://www.db-thueringen.de/servlets/DocumentServlet?id=14089>

# A LONG RANGE PASSIVE UHF TRANSPONDER ASIC WITH TEMPERATURE SENSOR

Tobias Feldengut, Stephan Kolnsberg, Rainer Kokozinski

Fraunhofer IMS, Duisburg

## ABSTRACT

Recent development in UHF RFID Tags has been focused on the optimization of the powering and communication range of the reader/tag system [1]. The use of low threshold Schottky-diode rectifiers and the rigorous minimization of the tag power consumption have yielded read ranges of more than 10 m for simple identification tags. Sensor transponders that serve as nodes in wireless networks require a more complex chip architecture with a stable, regulated supply voltage and precise current- and voltage references. The analog/digital conversion of sensor data leads to short periods of large current consumption on the tag side. A passive UHF sensor tag was designed in a 0.35  $\mu\text{m}$  CMOS process with Schottky diodes and double poly layers. The tag operates in the 868 MHz ISM band and the air interface is compatible to the ISO 18000-6 standard. The tag with temperature sensor consumes up to 10  $\mu\text{A}$  from the DC supply, which leads to an operation range of more than 4 m. The data rate, the size and the maximum range of each sensor node are significantly improved in comparison with existing LF and HF solutions.

**Index Terms** Passive, Temperature Sensor, Transponder

## 1. INTRODUCTION

Large, self-organizing and self-healing sensor networks to monitor environmental conditions such as temperature or pressure are a key technology for future concepts for a networked physical world. As of today, the available sensor nodes are relatively large, heavy, costly, and high maintenance. However, envisaged scenarios of smart dust and ambient intelligence, as well as near-term goals such as innovative supply chain management, rely on the availability of very small and light transponder tags. Therefore, research has focused on using RF energy to create a power supply for transponder ASICs, obviating the need for a battery.

While many existing passive sensor transponders operate in the magnetic near field via the coupling of two coils, UHF transponders use electromagnetic waves for the data and energy transfer between the reader and the tag.

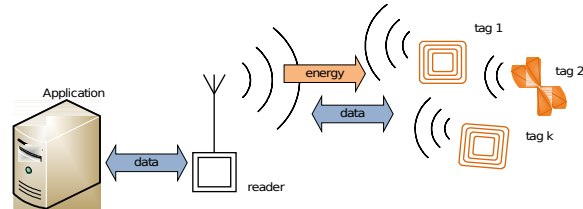

Figure 1: Passive transponder system

According to the Friis relation, the available power at the location of the tag is [3]

$$P = P_{EIRP} G \frac{\lambda^2}{(4\pi d)^2}, \quad (1)$$

where  $P_{EIRP}$  is the transmitted power from the base station,  $G$  is the antenna gain,  $\lambda$  is the wavelength, and  $d$  is the distance between the base station and the tag.  $P_{EIRP}$  is generally limited by national regulations. Equation (1) shows that the available power is as high as 94  $\mu\text{W}$  in a distance of 4 m between the base station and the reader. This power is more than sufficient for a transponder tag, which generally requires only 1 to 5  $\mu\text{A}$  of supply current at a supply voltage of less than 2 V. However, up to 90 % of the power that enters the rectifier circuit is dissipated in the rectifying diodes. The rectifying voltage multiplier is therefore a major bottleneck for the energy transfer.

The voltage amplitude at the input of the tag depends on the antenna radiation resistance, the chip input impedance, as well as the matching strategy. The voltage source amplitude from the antenna is proportional to the root of the radiation resistance  $R_{Rad}$  according to [3]

$$\hat{V} = 2\sqrt{2R_{Rad}P}. \quad (2)$$

The value of the radiation resistance is usually chosen around several hundred Ohms. Figure 2 illustrates the antenna-rectifier interface with simplified equivalent circuits.

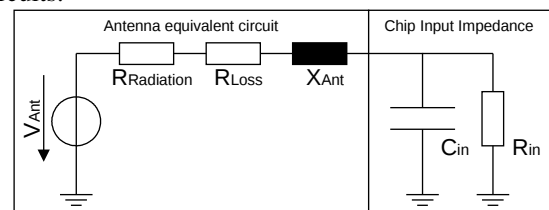

Fig. 2: Equivalent circuit for the antenna/rectifier interface

The input impedance depends on the current consumption of the tag circuits [1]. Many transponders have an input resistance of several kilo Ohms with an additional input capacitance in the order of 1 pF. If the antenna loss resistance is neglected and the imaginary parts are neglected, the voltage swing at the input of the rectifier is

$$\hat{V} = \frac{R_{in}}{R_{in} + R_{Rad}} 2\sqrt{2R_{Rad}P} \quad (3)$$

When the input power is low in a large distance between the reader and the tag, this amplitude is often below the threshold voltage level of the rectifying devices.

These UHF tags offer high data rates, a large operating range and a relatively small antenna size [4]. While they are already becoming widespread for classical identification purposes, the integration of additional functionality, such as sensors and the required readout circuitry, poses additional challenges. The chip architecture needs to be more complex, and each circuit block requires a different minimum supply voltage level. The A/D conversion of sensor data requires stable, ripple-free supply- and reference voltages, which creates higher demands on the current/voltage reference circuits and the voltage regulation.

The optimization of the rectifier and the antenna matching is also influenced by the additional circuitry for sensor tags. The DC output current of the rectifier is significantly higher because the chip architecture is more complex. The total current consumption is time

varying, with the largest load during the sensor readout. This variation of the rectifier load leads to an input resistance and an input capacitance that are not constant during the operation of the tag. This issue needs to be considered to achieve optimum antenna matching.

An ISO 18000-6 compatible UHF transponder tag was designed for a 0.35  $\mu\text{m}$  CMOS process with dual poly layers, EEPROM storage, and Schottky diodes. A temperature sensor and an ADC are integrated on the chip.

## 2. ARCHITECTURE

The architecture of the transponder ASIC is shown in figure 3. The top-level circuit blocks are the analog front-end, the temperature sensor, the A/D converter, and the digital logic with non-volatile storage. All circuits are integrated on an ASIC and the transponder contains no external devices except for the antenna. The analog front-end contains the power supply generation, a clock generator, and a modem for the forward and backward link communication (see figure 3). A reference voltage- and current are generated by a bandgap circuit, which also serves as the temperature sensor. This voltage reference is used for the biasing of analog circuits, voltage regulation, and A/D conversion. The modem implements the data interface between the RF signal and the digital part of the chip.

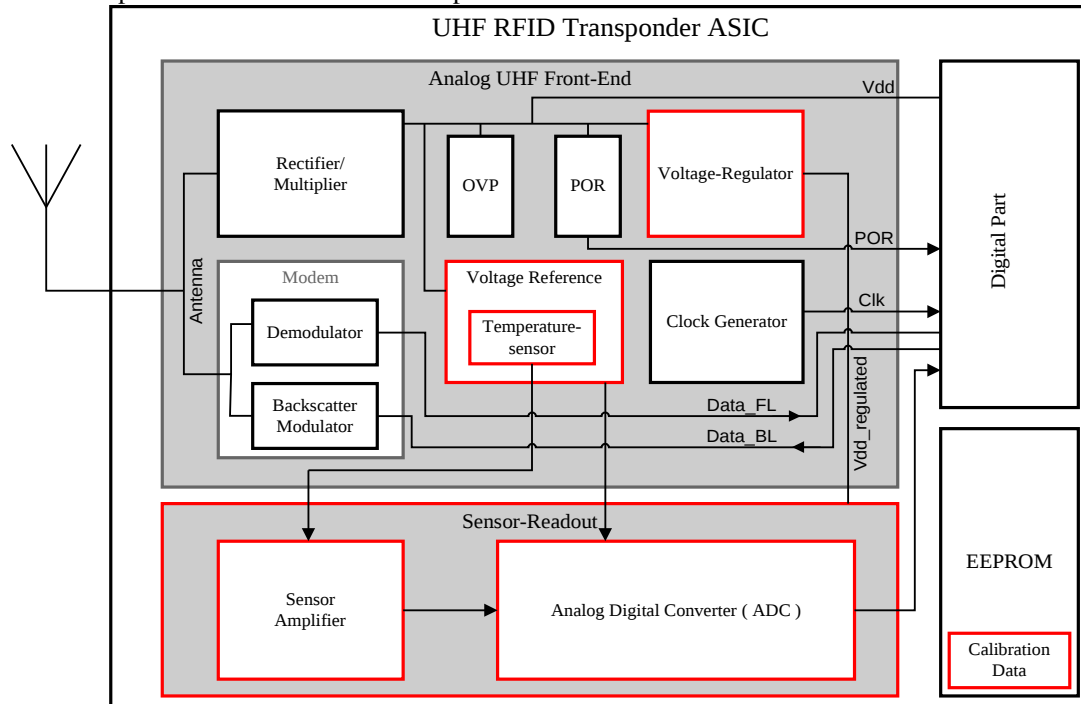

Figure 3: Transponder architecture and analog Front-End

The RF signal is ASK modulated for the forward data link according to ISO 18000-6. The demodulator extracts the digital information from the analog signal and generates a bit stream that is decoded by the digital part of the chip. For the return link communication, the input impedance of the tag is switched between two different states to modulate the tag's radar cross-section and the reflected wave.

The main tasks of the digital part of the chip are handling the communication protocol, implementing an anti-collision algorithm, and the (de-) coding of data. The digital logic is also used for synchronizing the local clock signal with the reader data. A low supply voltage and a low clock frequency are key measures to reduce the power consumption of all digital circuits. The non-volatile memory is required to store calibration data for every chip. EEPROM storage is used for this purpose. An additional DC-DC charge pump was implemented in order to reach the required voltage of 15 V for write operations.

### 3. ANALOG FRONT-END AND SENSOR

The analog Front-End is shown in figure 3. The design was optimized for low power consumption of all circuits, a high power conversion efficiency, reliable data modulation and demodulation at low modulation depth and varying input voltage swing, a stable regulated supply with small voltage ripple, as well as sufficient device protection.

The power supply generator consists of a Schottky diode charge pump circuit, a voltage regulator and an over-voltage protection. The power conversion efficiency of the charge pump mainly determines the operating range of the reader tag

system. Recent research has focused on the modeling and the optimization of the typical implementation as shown in figure 4 [2]. The optimum number of stages depends on the required output voltage, the output current as well as the Schottky diode properties. Simulations have shown that six stages allow the operation of the tag at minimum input signal amplitude. The output voltage VDC needs to reach at least 1.5 V for a proper operation of the tag. To achieve this requirement at a large distance from the base-station, the input resistance should be maximized and the input capacitance that is presented to the antenna should be minimized for a large voltage swing across the rectifying diodes. While state of the art identification tags can operate with less than 1  $\mu$ A DC current consumption, the sensor tag requires approximately 10 times more DC power. This additional current consumption has influence on the design of the diodes and the intermediate capacitors in the rectifier. The forward voltage drop across the Schottky diodes depends on the output current drawn from the rectifier output. Raising the diode area can effectively lower the forward voltage drop, but also raises parasitic capacitance and the reverse current. The size of the intermediate capacitors in the charge pump has an influence on the voltage ripple of VDC. For large output currents, the output voltage will decrease significantly if the capacitors are too small. The capacitor at the output of the rectifier has a value of 800 pF. Its size is only limited by the available chip area.

The DC output voltage from the rectifier varies with different load conditions and different RF input power. The over-voltage protection limits the voltage to a maximum of 3.6 V to insure sufficient device protection in close proximity to the base station.

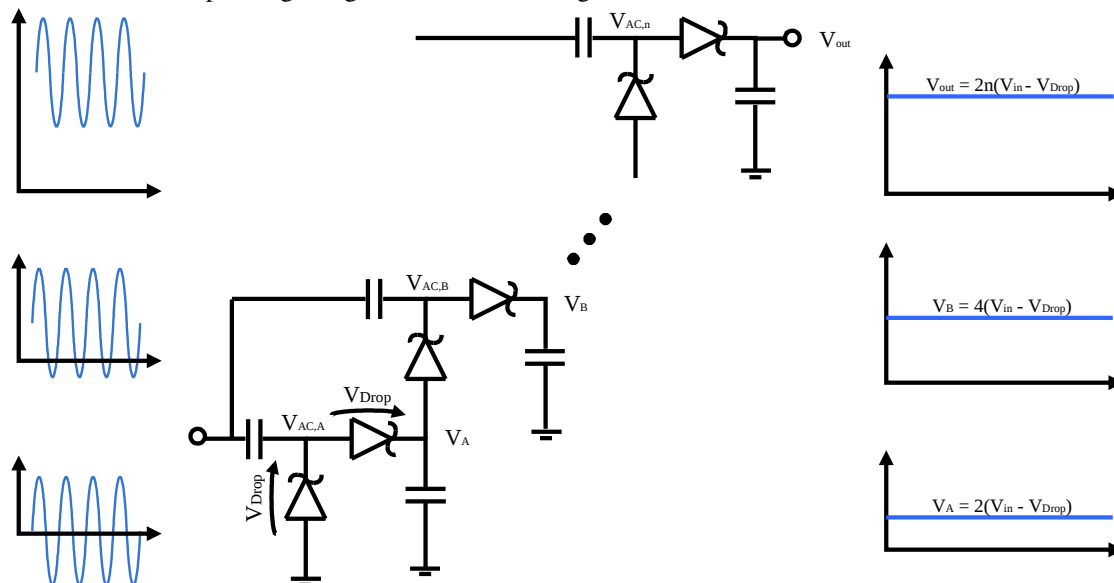

Figure 4: Schottky diode charge pump rectifier

The reference voltage for the regulation is generated by the bandgap reference circuit. The voltage divider which is comprised of the two resistors draws a constant current from the regulated voltage, so the resistors need to be very large. High resistance poly resistors were used to implement a 10 MOhm resistance. Identification transponders do not require a precise, temperature-independent reference source; if a voltage regulation is implemented, a simple, temperature-dependent reference is often sufficient. For the AD conversion of sensor data, however, a temperature independent reference is required. A typical low voltage bandgap reference circuit was therefore implemented (see figure 5). It generates a temperature independent reference voltage and the reference currents for the biasing of all analog circuits. This circuit also serves as the temperature sensor, as the voltage at node Vsens is dependant on the absolute temperature on the chip. The operational transconductance amplifier in the middle requires a certain supply voltage and current in order to provide enough gain and bandwidth.

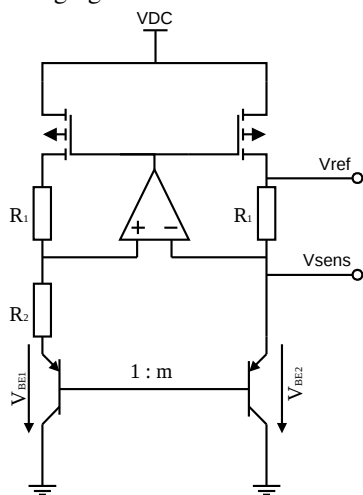

Figure 5: Bandgap reference circuit (startup not shown)

A simple ASK (Amplitude Shift Keying) modulation is used for the forward link communication from the base station to the transponder. This modulation type allows a simple and current efficient demodulator circuit at the tag input, as shown in fig. 6 [1]. It consists of an envelope detector, an average detector, and a hysteresis comparator. A small Schottky diode charge pump with two low-pass filters is used for the extraction of the envelope and the average signal. The demodulator has an input capacitance and a finite input resistance, so it represents an additional load to the antenna signal. The design of the circuit is optimized for low power consumption from the DC voltage as well as high input impedance.

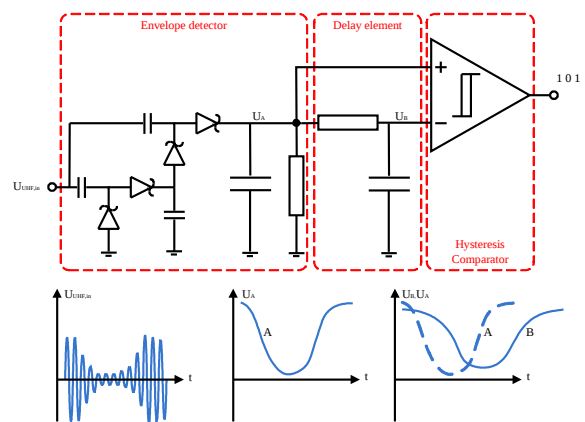

Figure 6: ASK demodulator

The input stage of the hysteresis comparator uses the unregulated supply voltage to achieve a large CMRR (Common Mode Rejection Ratio) in close proximity to the reader. This allows a correct demodulation at relatively large input signal amplitudes, when both the reference and the envelope signal have high amplitude.

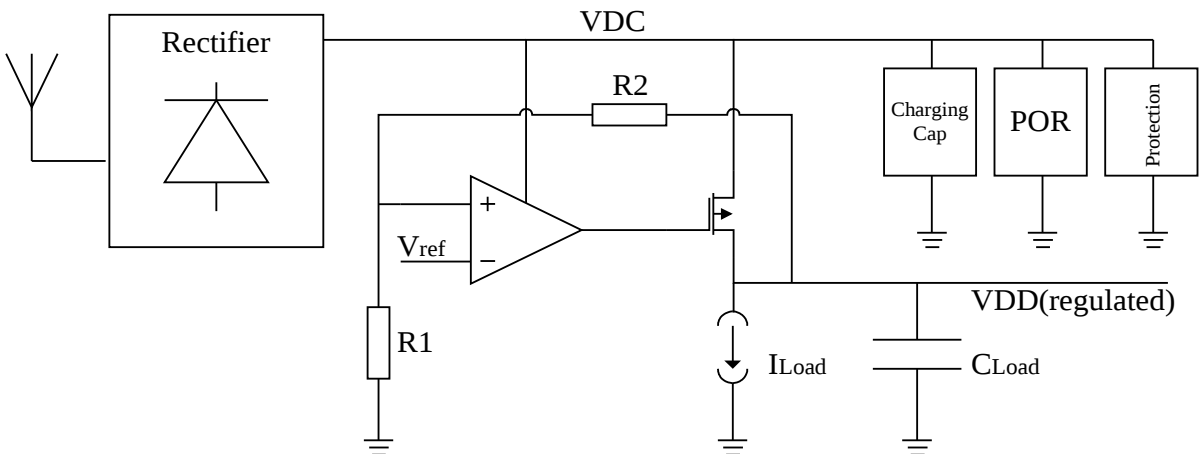

Figure 7: Power supply and low drop out voltage regulator

Backscattering communication is used for the data transfer from the tag to the base station [4]. The tag modulates its own radar cross section by switching between two different input impedances, representing the two modulation states, which can then be detected by the reader.

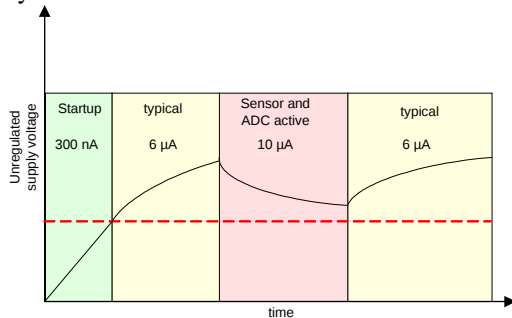

Figure 8: Supply Voltage at varying current consumption

The temperature sensor and the ADC consume additional power, so that the supply voltage is lower than typical (see figure 8). The current consumption during the startup is less than 300 nA, the typical case is 6  $\mu$ A and the maximum average current is 10  $\mu$ A during the sensor readout.

Figure 9 shows the layout of the designed test chip the chip area is less than 2 mm<sup>2</sup>. Passive devices consume a major part of this area, because large capacitors are required as short time energy storage, so that the supply voltages remain constant during short current peaks. Large resistors are required to reduce the current consumption in several analog circuit blocks.

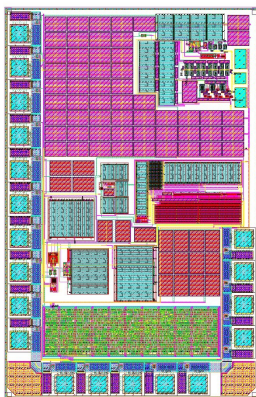

Figure 9: Chip layout

#### 4. CONCLUSION

A fully integrated passive sensor transponder tag was presented. A carrier frequency of 868 MHz is used for the energy and data transfer. The bandgap reference and the sensor readout circuits introduce additional requirements to the analog front end, because stable supply and reference voltages need to be generated, and the current consumption is raised significantly. The required current is 10  $\mu$ A and the operating range is 4 m.

#### 5. REFERENCES

- [1] U. Karthaus, M. Fischer. „Fully Integrated UHF Transponder IC With 16.7  $\mu$ W minimum RF Input Power“ IEEE Journal of Solid State Circuits, vol. 40, NO 10, Oct. 2003.
- [2] J.F. Dickson. “On Chip high Voltage generation for NMOS Integrated Circuits Using an Improved Voltage Multiplier Technique”
- [3] J.P. Curty, M. Declercq, C. Dehollain, “Design and Optimization of Passive UHF Systems” Springer, Berlin
- [4] K. Finkenzeller RFID Handbook, Radio Frequency Identification Fundamentals and Applications. 2nd ed. New York: Wiley, 2003.
- [5] K. Seeman, R. Weigel, “Ultra Low Power Rectification in Passive RFID Tags at UHF Frequencies”
- [6] A. Shamel, A. Safarin, A. Rofougaran, M. Rofougaran, F. De Flaviis “Power Harvester Design for Passive UHF RFID Tag using a voltage Boosting Technique”, IEEE Transactions on Microwave Theory and Techniques, Vol. 55. No. 6, June 2007 pp. 1087 – 1097.