

# DYNAMIC MEASUREMENT OF BODY SWING IN WALKING AND JOGGING BY WEARABLE SENSING SYSTEM

*Shigeru TAKAYAMA, Yuuki MATSUDA and Komyo KARIYA*

Fac.Sci.&Eng., Ritsumeikan Univ.BKC, Shiga, JAPAN

**Abstract** – This paper shows the dynamic measurement system and result of body inclination in walking by monitoring acceleration at waist. To monitor the acceleration in walking, the sensing system had been constructed as a wearable and small scale wireless network system (body area network sensing system [BANSS]) put on body. BANSS is constructed with a host system and plural sensing nodes. Sensing node has sensors, microprocessor and near field communication device (NFCD). In this study, the sensing node measures the acceleration at waist of user in walking, and sends them to the host system regularly. By analysing the acceleration data at host system, the situation of body inclination in walking was estimated dynamically. It has been confirmed that the body inclination generates for everybody regardless their consciousness.

**Keywords** : sensing system, body inclination, dynamic measurement

## 1. BASIC INFORMATION

In daily life, quality of life (QOL) is the highest concern for all of people. They hope to keep it well and enhance it. Parameters of QOL are many kinds and different to each person. The parameters are concerning to the situations of living, health, family, friends, job, money, meal, hobby, social activity and so on. Especially, physical condition like health is the most basic and indispensable parameter. The physical condition depends on physical activity in daily life and changes dynamically. Then, to know the state of physical condition in detail, it is necessary to measure that continuously in daily life. Wearable and wireless body area network sensing system (BANSS) is the most suitable system to measure the dynamical physical condition continuously. Concerning the measurement system of body motion in walking, there are several kinds[1-5]. In this study, to detect body inclination in walking, BANSS collects the acceleration at waist dynamically, analyses the data and sends the information to host system. The body inclination in motion becomes the cause of heavy load and strong pain at a hip joint and a knee. Most of people do not feel their body inclination in daily life. The detection of body inclination in walking is to discover the sign of them.

## 2. BODY AREA NETWORK SENSING SYSTEM -BANSS-

To measure physical conditions in motion like walking, running and various kinds of physical activities in daily life, there are several parameters which are heart rate(HR), SPO2(Oxygen density in blood), body temperature, skin temperature, accelerations at many points of body (shoulders, waist, knees and feet [ankles]), impact transmitting in bones and so on. The measuring points of these parameters are distributed on body area. And users should be not limited their behaviours in motion by devices and wires of the monitoring system. Then, the formation of sensing system should be light and easy to use, wearable and near field wireless network to communicate measuring data and commands on and around body area. In this paper, that system is called as the wearable and wireless Body Area Network Sensing System (BANSS). Fig.1 shows the conceptual construction of the wearable and wireless BANSS.

This system is classified into 2 kinds of subsystem. They are Sensing Nodes and a Wearable or Portable Host System. The sensing node is constructed with Sensors, Analogue-Digital Converter, Peripheral Interface Controller, some kinds of memory and Near Field Communication Device(NFCD). Now Zigbee communication device is used. The mounted sensors are Heart Rate sensor, SPO2 sensor, 3D acceleration sensor, temperature sensor and impact sensor(strain gauge). In future, we will mount more kinds of sensor.

The wearable / portable host system is constructed by Near Field Communication Device(NFCD), Micro processor unit, some kinds of memory, Long Distance Communication Device(LDCD) and Sound Visual Human Interfaces(SVHI). NFCD is the communication device with sensing nodes attached on body, and LDCD is with family and home doctor. By using LDCD, they can monitor the physical condition of subject person and take the urgency information from him. Sound Interface is Earphone to give some advices and information of physical condition. Visual Interface is LCD monitor to show the situation of physical parameters in motions.

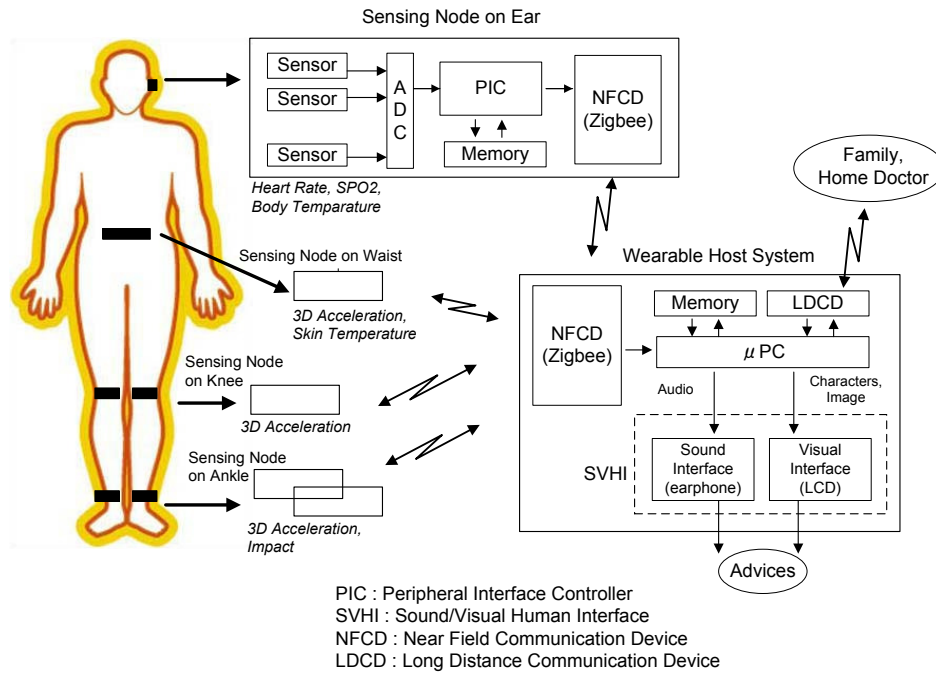

Fig.1 Concept of body area network sensing system (BANSS)

### 3. MEASUREMENT OF BODY INCLINATION IN WALKING

Using a function of BANSS, body inclination in walking has been measured dynamically. Fig.2 shows the concept of the detection of body inclination by acceleration sensor. User puts 3D acceleration sensor on waists. The data of X axis of the sensor output expresses the movement of up-down direction of user. The data of Z axis expresses the movement of front-back direction. And the output signal of Y axis of the sensor expresses the movement of right-left direction. Fig.3 shows the detection of body inclination by analysing the signal of Y axis of acceleration sensor in

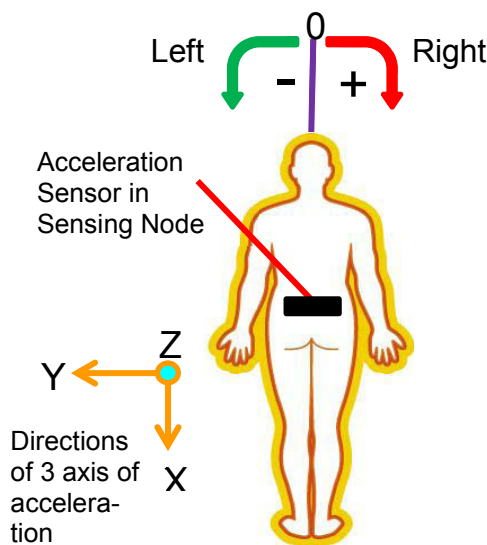

Fig.2 Concept of the detection of body inclination by acceleration sensor

walking. Fig.3(a) shows the output signal of Y axis of 3D acceleration sensor. It is seen that the signal is fluctuating around zero. The movement of right-left direction in walking is not so high speed. Blue line in Fig.3(b) shows the signal filtered by LPF (less than 0.1 Hz). The filtered signal has the bias changing slowly. To detect the bias locally, the average of the filtered signal in a constant time interval is calculated. The series of green squares in Fig.3(b) shows the fluctuation of local average each 30 sec.. In Fig.3(b), it is confirmed that the series of local average each 30 sec. has shifted to left side. By this observation, it has been estimated that the body inclination of user is right in walking.

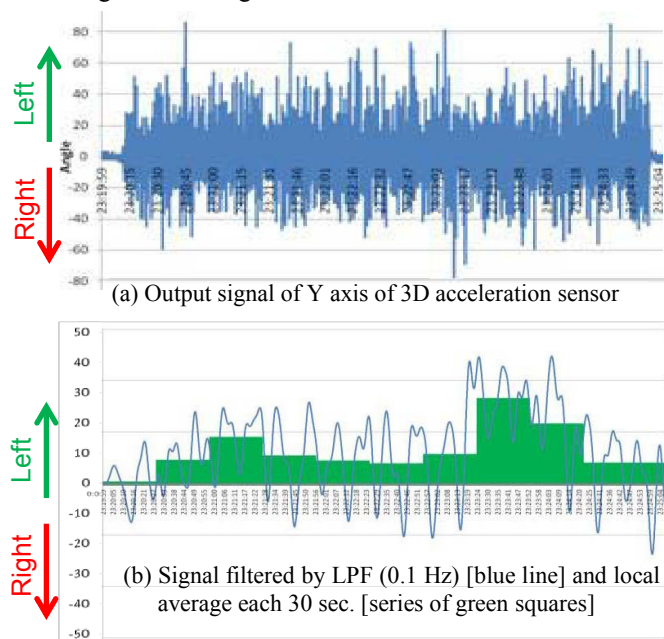
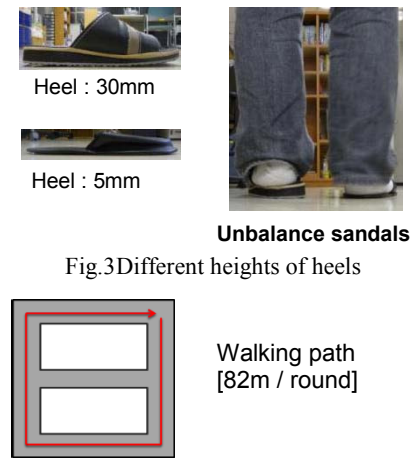

Fig.3 Detection of body inclination by analysing the signal of Y axis of acceleration sensor



- 1<sup>st</sup> round walking with balanced sandals
- 2<sup>nd</sup> round walking with left low heel sandal
- 3<sup>rd</sup> round walking with right low heel sandal

Fig.4 Walking path

To confirm the system operation obviously, the body inclination by unbalance sandals was estimated. Fig.3 shows unbalance sandals. Fig.4 shows walking path, the distance of which is 82m/round. Subject walked three times around the square path. He used with balance sandals in the 1<sup>st</sup> walking, with left low heel sandal in the 2<sup>nd</sup> walking and with right low heel sandal in the 3<sup>rd</sup> walking. Fig.5 shows the estimated results. Using balance sandals, body inclination was zero mostly. On the other hand, using unbalance sandals, body inclination became left side by low heel on left side. As the left heel is lower than right heel, the acceleration to left side became strong in walking.

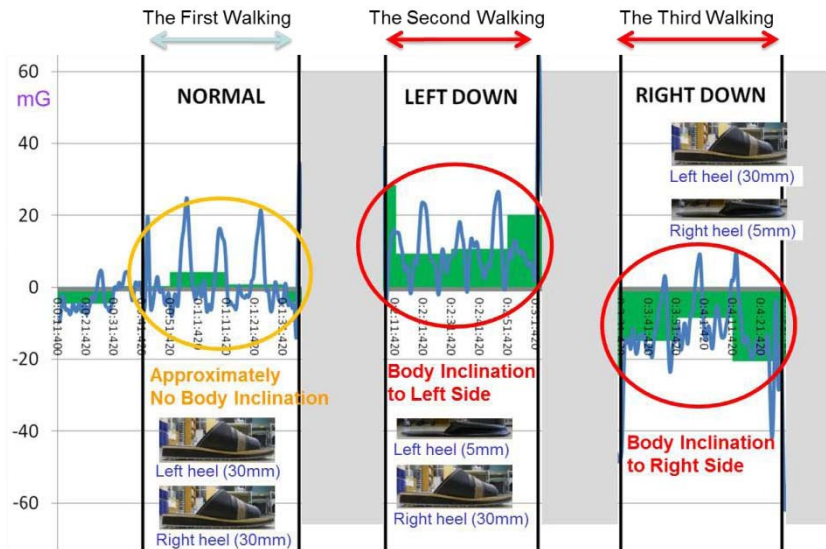
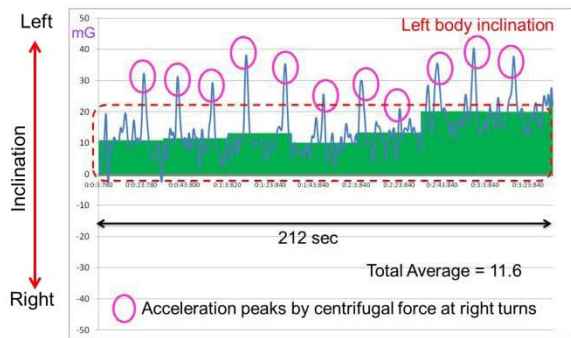

Fig.5 Different body inclinations by balance and unbalance heels

In contrast to that, as the right heel is lower than left heel, the acceleration to right side became strong in walking

By using this system, the body inclinations in walking of 5 Laboratory staffs were measured. They walked on same path 3 times continuously with their own shoes. As a remark, they have no consciousness concerning to body inclination at standing and in any motions in daily life. Fig.6 shows the measurement results. In Fig.6(a), acceleration signal has 11 peaks to left side. These are caused by centrifugal force at right turns. As the series of local average (green area) shift to positive, it is confirmed that the body



(a) in case of Male 32 years old



(b) in case of Male 24 years old

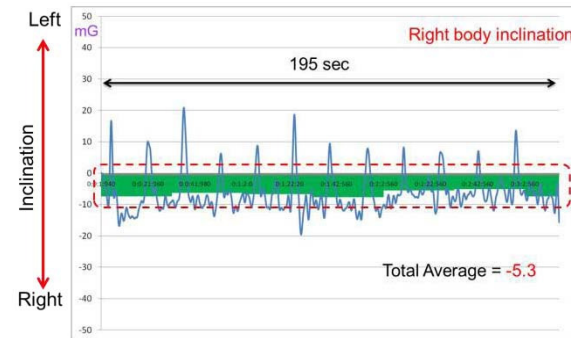

(c) in case of Female 29 years old

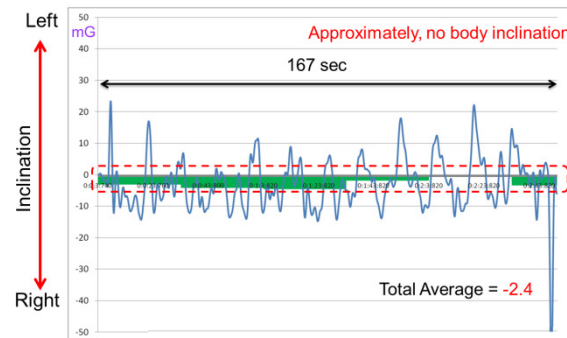

(d) in case of Male 23 years old

Fig.6 Estimation of body inclination in walking

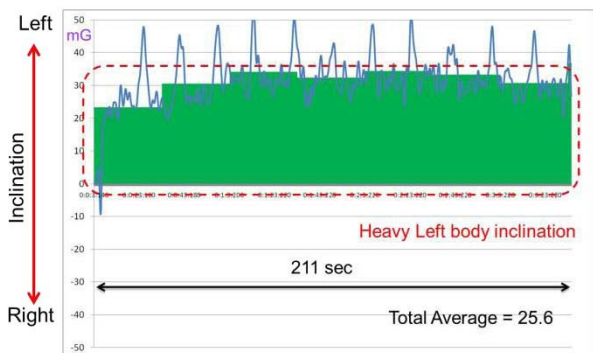

(e) in case of Male 49 years old

Fig.6 Estimation of body inclination in walking

inclination is left side. In Fig.6(b),(c), as the series of fluctuation of local average (green area) shift to negative, then, the body inclination is right side. In Fig.6(d), the series of local average are around zero. Then, the body inclination was not observed approximately. In Fig.6(e), the body inclination is heavy to left side. It seems that his waist(hip joints) and left knee have got strong load in walking.

### 3. MEASUREMENT OF BODY SWING IN JOGGING

Acceleration signal is caused by body swing. Then, by calculating the standard deviation successively, it is possible to estimate the range of body swing dynamically. Fig.7 shows the relation of horizontal body acceleration and a series of the standard deviation. Blue line is the time transition of the stand

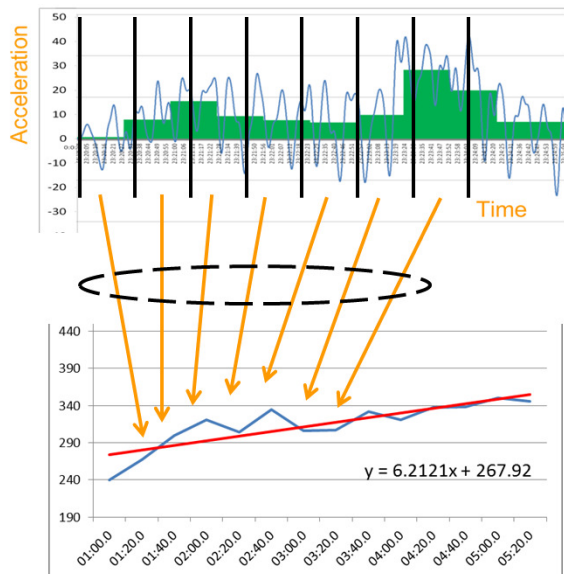

Fig.7 Dynamic situation of body swing by fluctuation of standard deviation

ard deviation each 20 sec.. As the standard deviation is increasing, it is confirmed that body swing becomes widely according to time. Red line is the 1st order approximation line.

The body swings of 5 persons in jogging are measured. They run on exercise treadmill indoor by 8km per hour. They repeated the exercise 5 times of jogging(5min.) and rest(6min.). As a remark, they have no consciousness concerning to obvious body swing in jogging in daily life. Fig.8 shows the measurement result of Male 22 years old.

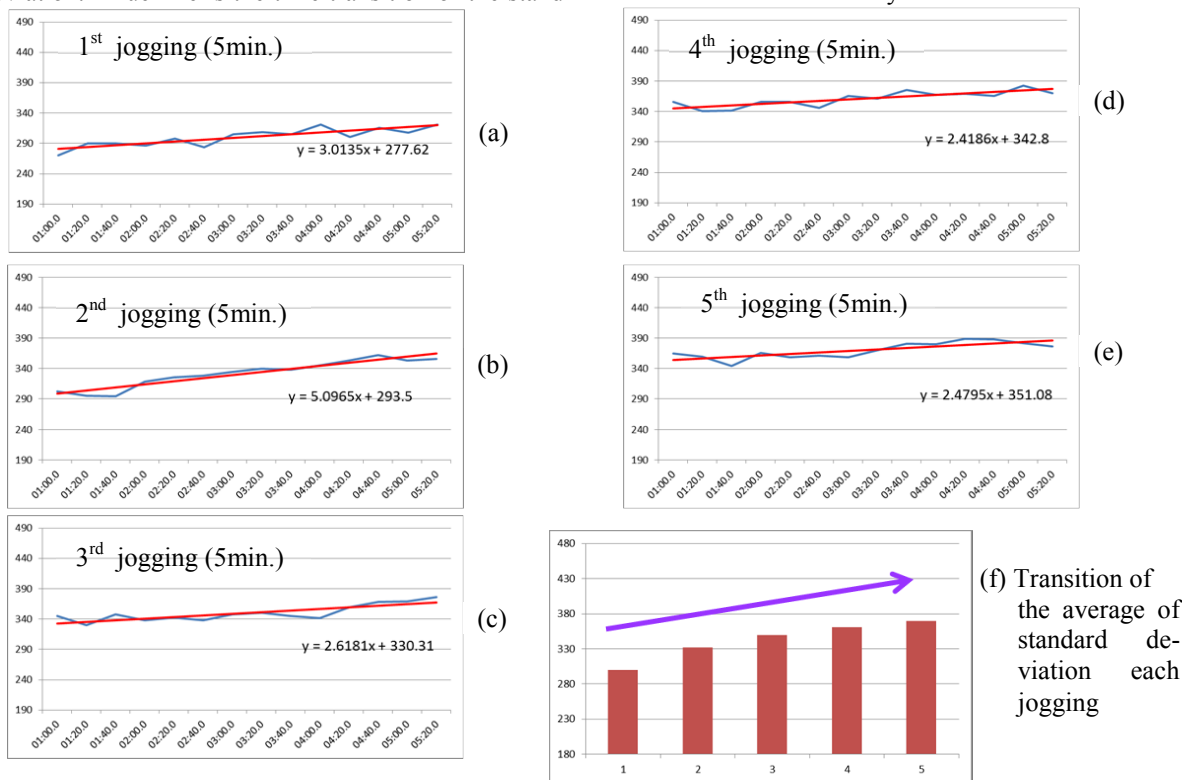

Fig.8 Time series of standard deviation by body swing in jogging each 5 min. [Male, 22]



The bias of standard deviations is middle level. In all joggings, all standard deviations were increasing. This means that the body swing became widely according to time. The average of standard deviation each jogging was also increasing. This means that the body swing became widely according to each jogging.

Fig.9 shows the measurement result of Male 22 years old. The bias of standard deviations is low level. This means that his body swing was very narrow and his jogging was very stable. But, the standard deviations were increasing slowly according to time, and also each jogging. Fig.10 shows the measurement result of

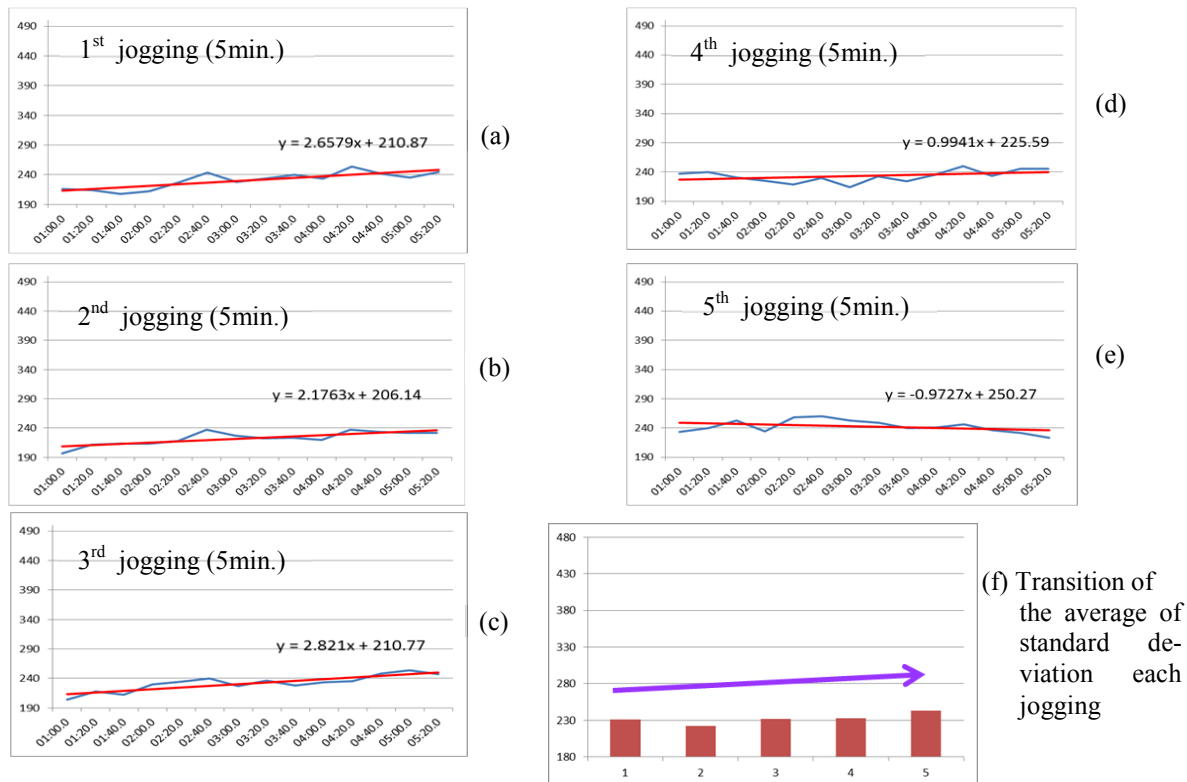

Fig.9 Time series of standard deviation by body swing in jogging each 5 min. [Male, 23]

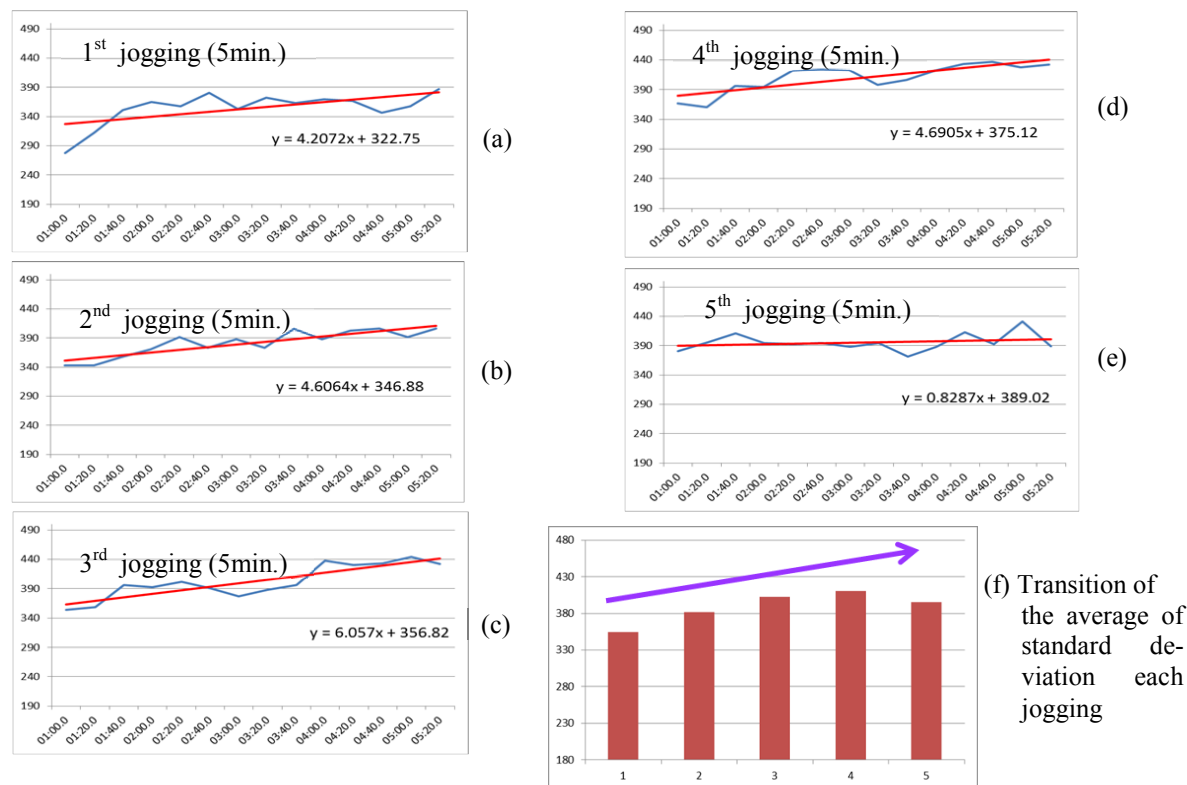

Fig.10 Time series of standard deviation by body swing in jogging each 5 min. [Male, 22]

Male 22 years old. The bias of standard deviations is high level. This means that his body swing was widely and his jogging was unstable. The increasing inclination of the standard deviation and the average are also confirmed obviously.

### 3. CONCLUSION

Body inclination and swing in motion cause unbalance of physical activity. They give heavy load to waist (hip joints) and knees of us. But, mostly they occur without consciousness at the beginning. By using wearable and wireless body area network sensing system (BANSS), it was confirmed that the body inclination and swing in walking and jogging were estimated dynamically. As future works, by the measurement of the body inclination and swing in walking and jogging for long time, postures and fatigue of subjects in the motion will be estimated. In addition to that, BANSS is useful tool to measure the physical parameters at various parts on body and estimate physical condition dynamically in motion. By compact and robust design, that does not become obstacle to various motions. The application fields of BANSS will spread more and more.

### REFERENCES

- [1] Naofumi Tanaka, Shigeru Sonoda, Yoshihiro Muraoka, Yutaka Tomita, Naoichi Chino, " Reproducibility and Validity of Gait Analysis Using Portable Accelerometer ", *Jpn J Rehabil Med*, 1.33, pp.549 – 553, 1996.
- [2] Yosinori Nishijima, Tatuo Kato, Takahide Baba, Masatada, Yoshizawa," Effect of Stride Frequency on EMG during Level Walking and Stair Ascending", *Walking Research*, 7, 2003.
- [3] Hisao Oka and Tomonori Inoue, "Monitoring of physical Activity by Accelerometer", *Technical Report of IEICE*, MBE98-50, 1998.

---

**Author(s):** Prof.Dr.Shigeru TAKAYAMA, Mr.Yuuki MATSUDA, Prof.Dr.Komyo KARIYA ; Dept.E.E.Engng., Fac.Sci.&Eng., Ritsumeikan Univ.BKC, ; Noji, Kutsatsu, Shiga, 525-8577, JAPAN ; Phone : +81-77-561-2685, Fax : +81-77-561-2663, E-mail : s-tkym@se.ritsumei.ac.jp